

SANIVITE Drain Pump

CONNECTIONS



DISHWASHER



SINK



SHOWER



BATHTUB



LAUNDRY SINK



WASHING MACHINE

APPLICATIONS



RESIDENTIAL



COMMERCIAL



CommercialGrade

Example of installation. Follow local plumbing codes for actual install.

The **Sanivite drain pump** is used to pump gray water away from a variety of fixtures in **commercial and residential applications**. The system is able to discharge the waste up to **16 feet vertical and/or 150 feet horizontal**. This model was designed to sustain the toughest applications as it is capable of **handling hot water and grease**.

- Discharges the waste through a 1", 1-1/4" or 1-1/2" rigid pipe. A non-return valve is included on the discharge elbow assembly provided with the system. This elbow can be rotated 360 degrees depending on the discharge installation.
- Has been designed with a 1-1/2" vent connection on top of the lid. All plumbing codes require connection to a vent system. Either inlet located on top of the housing can be used for the vent or as an inlet. Please note that the vent system should be a two-way air vent as air needs to freely flow both ways. Note: The use of mechanical vents, air admittance valves or similar devices is not permitted.
- Discharges **gray water from a kitchen sink, bath/shower, dishwasher, washing machine** (indirect connection via laundry sink). The gray water will drain into the system via **three inlets**, two 2" inlets (with built-in check valves) on either side of the housing and one 1-1/2" inlet on top of the enclosure.



CommercialGrade

PUMPING DISTANCE

16 Ft



150 Ft

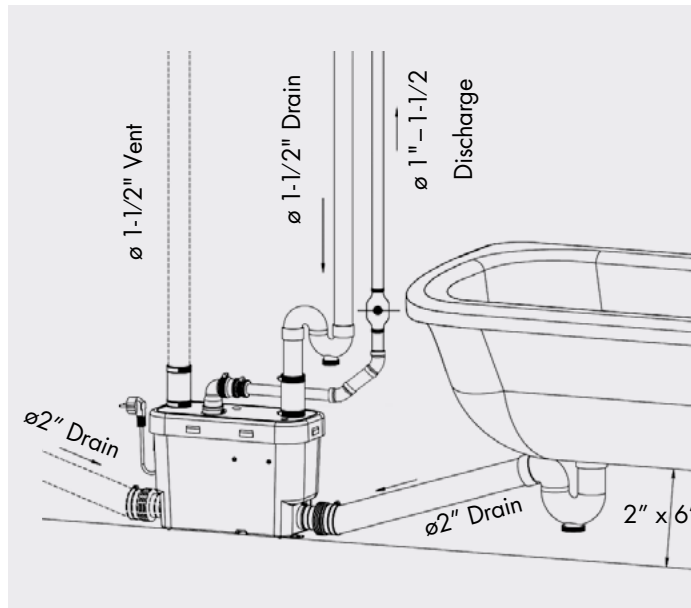

AN EASY SOLUTION FOR A KITCHEN INSTALLATION OR FOR ANY GRAY WATER APPLICATION

Drain pump small enough to fit inside a kitchen cabinet with the **capability to handle hot water and grease buildup**.

The perfect quiet solution **designed with low drain inlets** which facilitate the installation of showers and bathtubs in **heavy-duty residential or commercial applications**. Built-in check valves prevent any backup into the connecting fixtures.



PLEASE CALL US TOLL-FREE AT
800-571-8191 (US) / 800-363-5874 (CDN)
 TO PURCHASE PARTS REFERENCED BELOW

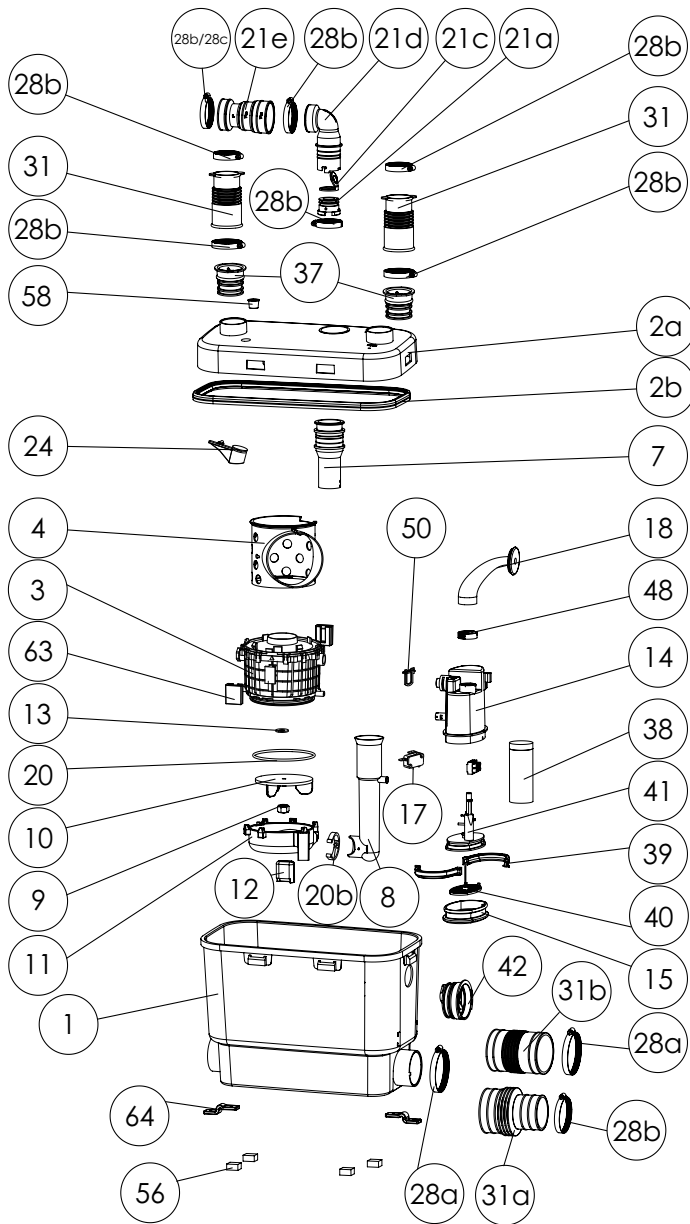

DIMENSIONAL DRAWINGS

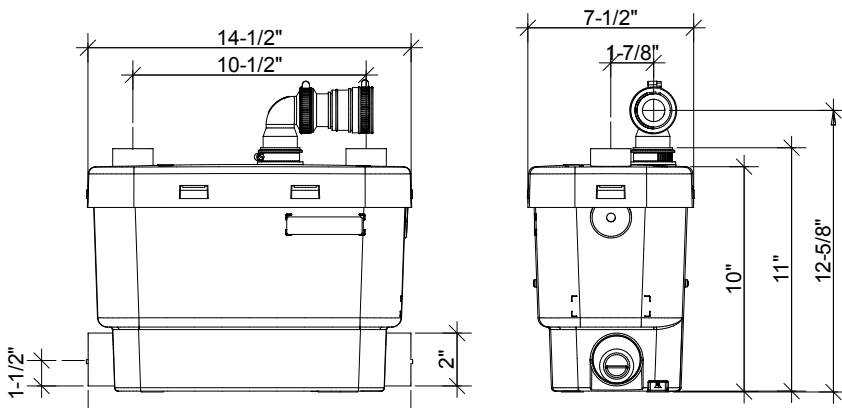

An easy solution for a kitchen installation, a remote laundry room or any gray water application.

TECHNICAL SPECIFICATIONS

Pump type:

Drain pump

Electrical:

120 V – 60 Hz / 4.5 Amps (Max) *

Motor:

0.4 HP oil-filled thermally protected motor

Capacitor rating:

18 microfarad

Operating Temperature:

140°F

Power cord length:

42-1/2 inches

Noise level:

≤ 44 dBA (Lp) (measured at 3 ft.)

Discharge pipe diameter:

1" - 1-1/2"

Discharge rate at 16 ft:

18 GPM

Discharge rate at 3 ft:

29 GPM

Shut-off head:

30 ft.

Normal running time:

3-5 seconds (Short bursts)

Capacity:

3.7 gallons / 14 liters

Inlets:

2" (sides), 1-1/2" vent (top)

Method of activation:

Membrane/microswitch

Shower/bathtub base height:

6" min

Weight:

16 lbs / 7.25 kg

Certifying agencies:

CSA (IPC, NSPC)

Recommended accessories:

Descaler, Sanialarm

Connections:

Sink, shower/bathtub, washing machine (indirect), dishwasher, laundry sink, etc.

* Measured using 1" discharge. Information will vary once the discharge size is increased. Consult with factory.

