

# VANITY BASIN: V1619/6/3

V1619/6/3 | 2000102805

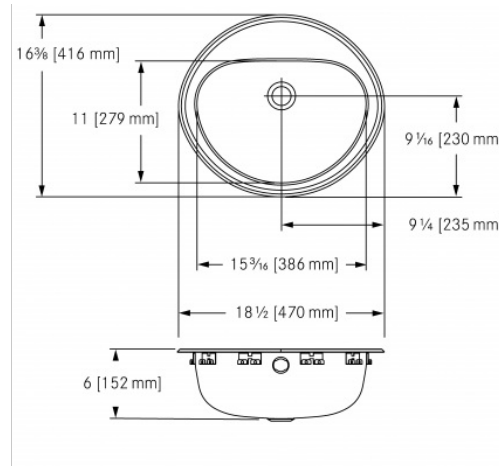

Single compartment self rimming vanity basin with faucet ledge. 18 gauge (1.2 mm), type 304 (CNS 18/10) stainless steel. Mirror finished rim, #4 satin finished bowl. Undercoated to reduce condensation and resonance. Includes factory applied rim seal, cutout template, and installation hardware. Certified to ASME A112.19.3-2008 / CSAB45.4-08.

Center back waste location, accepts 1 1/4" (32 mm) waste assembly (not included), integral overflow at front of bowl.

3 faucet holes 1 1/8" (28 mm) diameter, 4" (102 mm) centerset.

## TECHNICAL DATA

type of basin	vanitybasin
bowl depth	6"
Bowl finish	SATIN-FINISHED
Bowl front to back	11"
Bowl left to right	15 3/16"
gross weight	4.50 kg
material	STAINLESS-STEEL
material code	1.4301 Chrome Nickel steel V2A
material thickness grade	18 gauge (1.2 mm)
Overall front to back	16 3/8"
Overall left to right	18 1/2"
overflow	no
number of faucet holes	3
faucet hole diameter	1 1/8"
Faucet ledge	yes
type of waste kit	optional grid strainer
undercoated	yes
waste hole position	centre back
net weight	3.80 kg
Faucet ledge position	Back

## PROJECT INFORMATION

Item Location \_\_\_\_\_

Project Number \_\_\_\_\_

Quote Number \_\_\_\_\_

Notes \_\_\_\_\_

Engineer's Approval