

16.5" Simmons [SINGLE 4.8 L FLUSH TOILET]

FEATURES

- 16.5 inches high: ideal for comfort in use
- 4.8 Liter Hurricane flush
- Slow close UF toilet seat
- 2 1/8 inch completely glazed trapway
- 3 inch diameter flush valve
- Anti-siphon quiet refill valve, non ballcock style
- Vitreous china with a gravity fed Hurricane siphonic action bowl flush design
- Large water surface in bowl
- Chrome flush lever
- 12 inch rough in
- Available in white finish
- Limited 2 Year Warranty



COMPLIANCE CERTIFICATIONS

Specified model meets or exceeds the following:

- ASME A112.19.2-2003 & IAPMO/ANSI UPC1-2003
- CSA B45.0-02, B45.1-02 and B45S1-04
- MaP approved for 800 grams/1.75lbs of solid waste removal on the full flush
- WaterSense approved, meets EPA Criteria



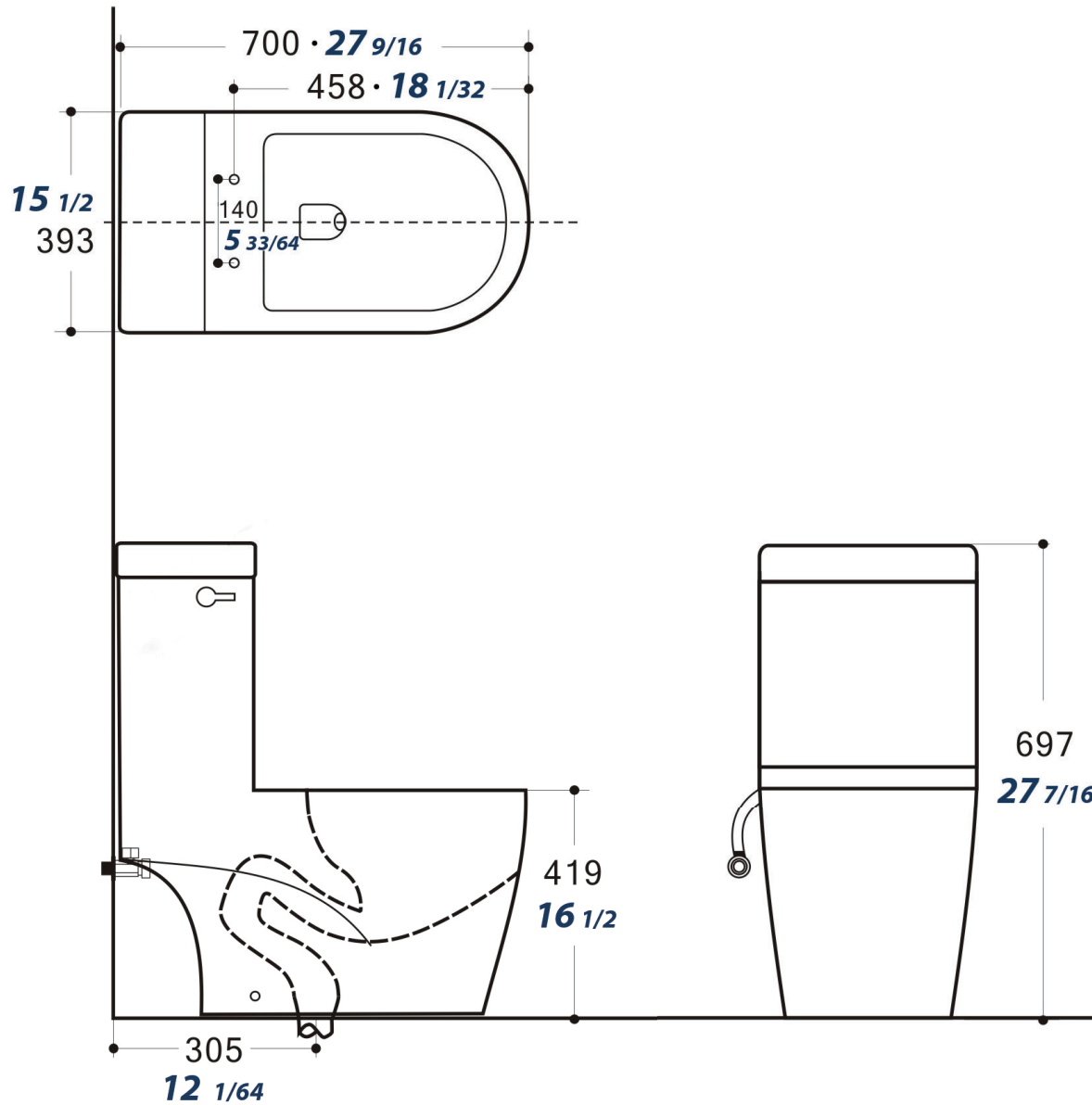

Model #	Description	Weight (lbs)	Shipping Dimensions	Cubic Feet
BT1016548	Lever Flush, 4.8L, White, 16.5"	105.8		7.77

These dimensions are nominal and are subject to change without prior notice.
 Fixture performance and specifications meet or exceed, ANSI/ASME A112.19.2-2008/CSA B45.1-2008 Certification Standard