

INSTALLATION INSTRUCTIONS

Landfair™ Wall Mounted Accessories

Robe Hook – Model D35107.210

Towel Ring – Model D35107.190

Towel Bar 24" – Model D35107.240

Tissue Holder – Model D35107.230

Thank you for selecting DXV by American Standard. To ensure that your installation proceeds smoothly, please read these instructions carefully before you begin.



AMERICAN STANDARD

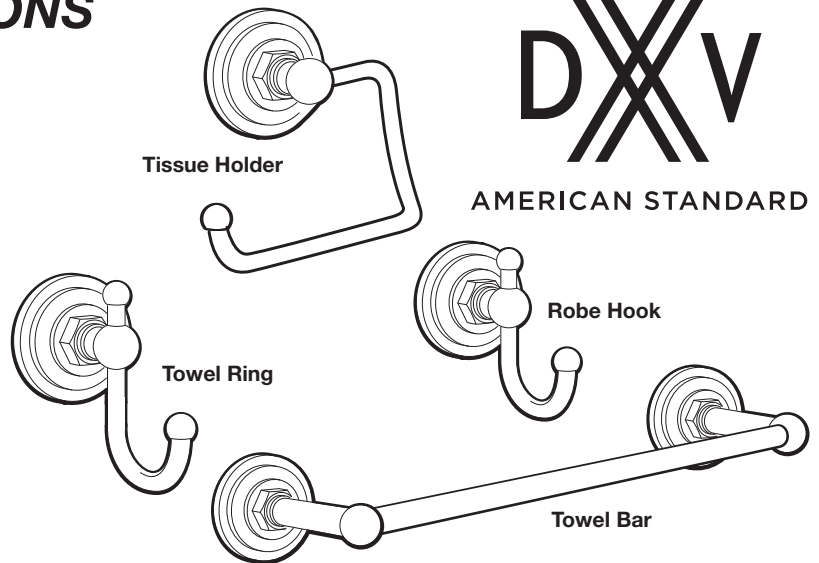

RECOMMENDED TOOLS AND MATERIALS



Phillips Screwdriver



Regular Screwdriver

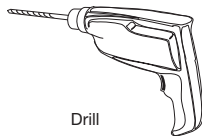

Drill



Tape Measure



Level

ROUGHING-IN DIMENSIONS:

Towel Ring

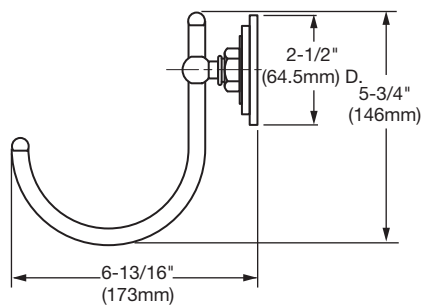

Tissue Holder

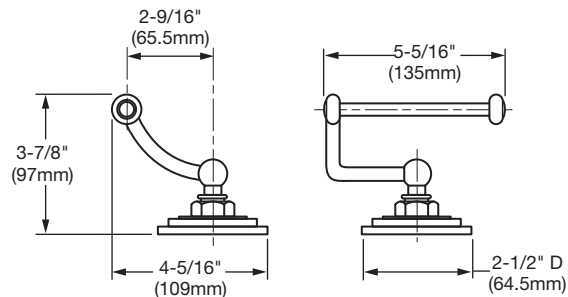

Robe Hook

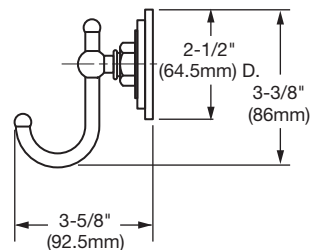

Towel Bar

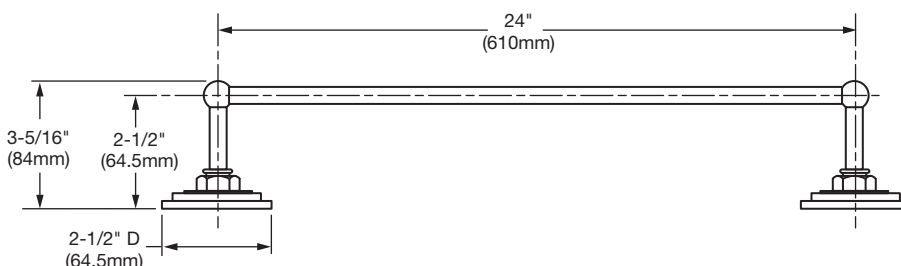

Available Finishes

POLISHED CHROME	100
BRUSHED NICKEL	144
PLATINUM NICKEL	150

In the United States:

DXV by American Standard
One Centennial Avenue
Piscataway, New Jersey 08855
Attention: Director of Customer Care

For residents of the United States, warranty information may also be obtained by calling the following toll free number: (800) 227-2734
www.DXV.com

In Canada:

DXV by American Standard
5900 Avebury Road
Mississauga, Ontario
L5R 3M3
Canada

Toll Free: 1-800-387-0369
Local: 905-306-1093
Fax: 1-800-395-1498
www.DXV.ca

In Mexico:

DXV by American Standard
Via Morelos 330
Col. Santa Clara Coatitla
Ecatepec, Estado de México 55540

Toll Free: 01-800-8391200
www.DXV.mx

SAVE FOR FUTURE USE

1 INSTALL WALL BRACKET

- The wall mounted accessories (1) works best if secured to a wall stud or cross brace within the wall, using the SCREWS (2) supplied.
- If the WALL MOUNTED ACCESSORIES (1) are to be installed on a tile or plaster wall the ANCHORS (3) and SCREWS (2) should be used.
- Determine desired height and location (optional) and mark a center line. **IMPORTANT: The *center line for the MOUNTING PLATE (4) must be level or the wall accessory will not mount level.** Using the MOUNTING PLATE (4) as a template mark the three spots for the ANCHORS (3). If MOUNTING PLATE (4) is secured to a stud or cross brace drill small pilot holes for SCREWS (2).
- **For installations on drywall or tiled walls:** Use ANCHORS (3) and SCREWS (2) for securing MOUNTING PLATE (4) to finished wall. Drill two 1/4" dia. holes a minimum of 1-3/4" deep. Insert the two ANCHORS (3) flush with face of the finished wall.
- Secure MOUNTING PLATE (4) to wall with SCREWS (2).

2 INSTALL ACCESSORY

- Install WALL MOUNTED ACCESSORY (1) onto installed MOUNTING PLATE (4). Push WALL MOUNTED ACCESSORY (1) flush against finished wall and tighten SET SCREW (5) with HEX WRENCH (6) supplied with accessory.

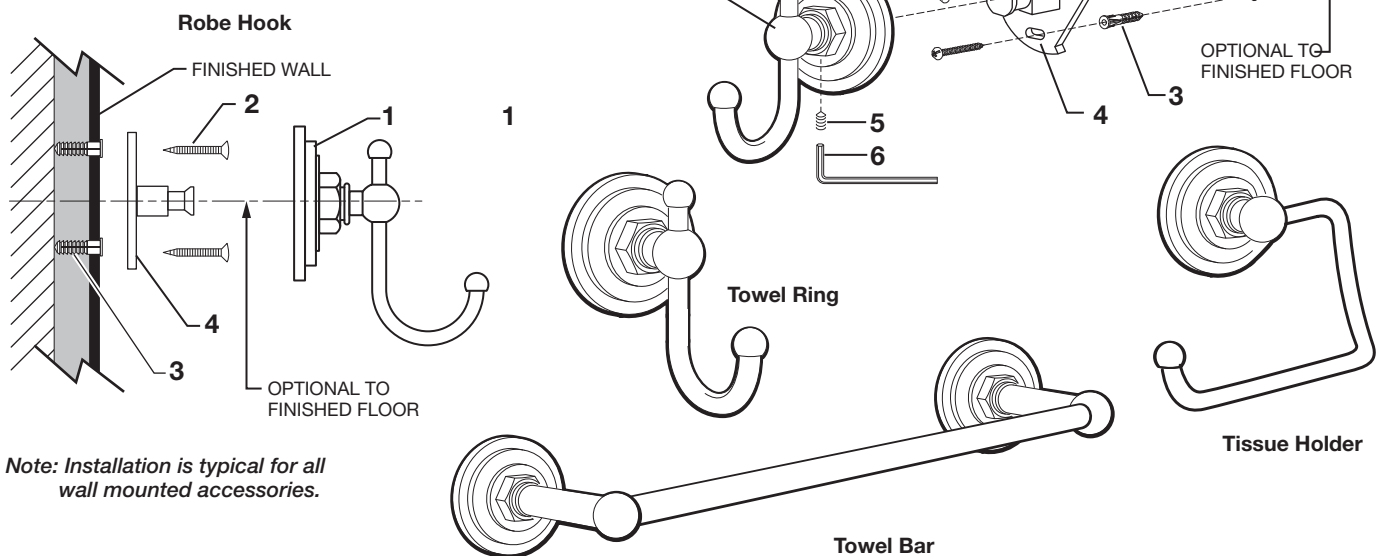

Note: Installation is typical for all wall mounted accessories.

3 INSTALL 24" TOWEL BAR

- The TOWEL BAR (1) work best if secured to a wall stud or cross brace within the wall, using the SCREWS (2) supplied.
- If the TOWEL BAR (1) is to be installed on a tile or plaster wall the ANCHORS (3) and SCREWS (2) should be used.
- Determine desired height and location (optional) and mark a center line. **IMPORTANT: The *center line for the MOUNTING PLATES (4) must be level or the wall accessory will not mount level.** Using the MOUNTING PLATE (4) as a template mark the six spots for the ANCHORS (3). If MOUNTING PLATE (4) is secured to a stud or cross brace drill small pilot holes for SCREWS (2).
- **For installations on drywall or tiled walls:** Use ANCHORS (3) and SCREWS (2) for securing MOUNTING PLATE (4) to finished wall. Drill six 1/4" dia. holes a minimum of 1-3/4" deep. Insert the three ANCHORS (3) flush with face of the finished wall.
- Secure MOUNTING PLATES (4) to wall with SCREWS (2).
- Install TOWEL BAR (1) onto installed MOUNTING PLATES (4). Push TOWEL BAR (1) flush against finished wall. Tighten SET SCREW (5) on both ends of TOWEL BAR (1) with HEX WRENCH (6) supplied with accessory.

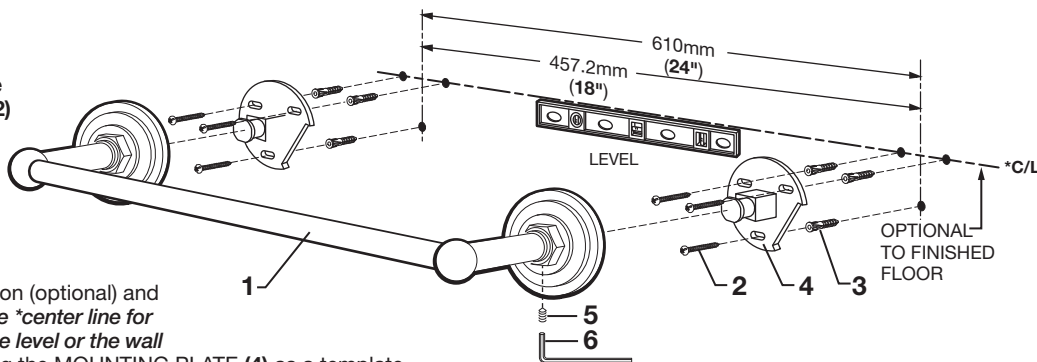

*FROM CENTER TO CENTER OF WALL BRACKETS
 *NOTE: MEASUREMENT IS APPROXIMATE ONLY, PLEASE USE BAR AS TEMPLATE FOR ACTUAL CENTER TO CENTER MEASUREMENTS.