



Victorian 67

Product #: 43201

67" x 29" x 31 1/4" | Immersion Depth: 12 7/8"

FINISH

- Interior: Smooth, high gloss acrylic
- Exterior: Smooth, high gloss acrylic
- Comes standard with factory installed chrome legs

LEG UPGRADES

- Brushed Nickel (Part Number: #43990)
- White (Part Number: #43992)
- Black (Part Number: #43993)
- Oiled Rubbed Bronze (Part Number: #43994)

allow 2-3 weeks for plating of the legs for finishes other than chrome

ACCESSORIES

- Chrome Clicker (Part Number: #01076)
- Chrome plug & chain (Part Number: #01074)
- Brushed Nickel plug & chain (Part Number: #01073)

WEIGHT

- 39kg | 75lbs

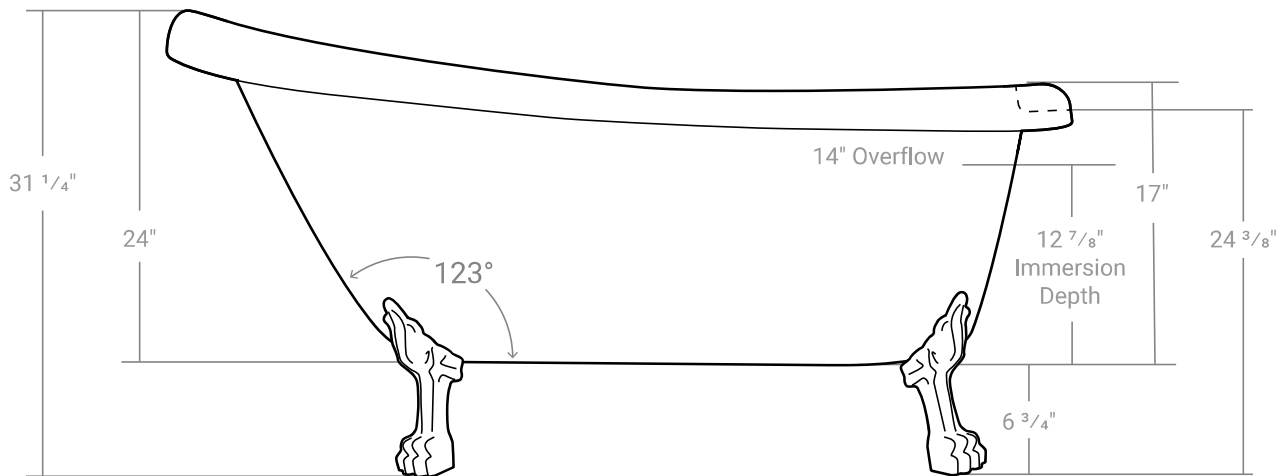
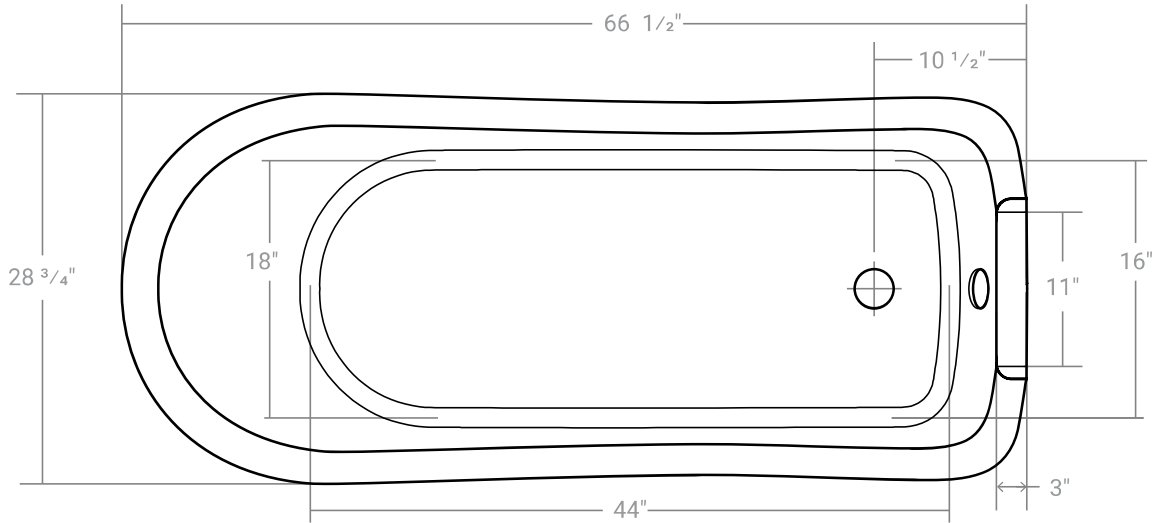

Acritec Industries Corp.

27049 Gloucester Way
Langley, B.C. V4W 3Y3

Tel: 604.607.0856

Fax: 604.607.0857

Email: info@acritec.com

Website: www.acritec.com

In keeping with our policy of continuing product improvement, Acritec Industries Corp. reserves the right to change product specifications without notice.

Important

*While we strive to provide accurate measurements for our customers, sometimes mistakes happen. Our goal is to help things run smoothly from shipment to installation, so if you notice any errors in our spec sheets, please let us know.

Our products are handmade & hand finished so you can expect a tolerance of $\pm \frac{1}{4}$ " on all measurements. We strongly recommend waiting until your ordered product is on-site before attempting any rough-in carpentry or plumbing.

If you want to verify any of our measurements, please feel free to call or email us.

*Drawings are not to scale