

**Features**

- No visible screw
- Water 1/2" male inlet NPT threaded or welded
- Shut-off valves included
- Solid brass construction
- Total adjustment of 19mm (3/4")
- Ceramic cartridge
- Included support for better stability during installation
- Possibility of 3 components (3 direct positions and 2 shared positions)
- 1 small handle used to adjust the temperature
- 1 handle used to select a component

Colors (Finishes)

- Chrome : BF1309-110

Certifications

The specified model meets or exceeds the following standards;

- ASME A112.18.1 / CSA B125.1

**Packaging**

- **Dimensions:** 362mm x 184mm x 191mm (14 1/4" x 7 1/4" x 7 1/2")
- **Volume:** 0.45 cu ft (0.013 cu m)
- **Total weight:** 5.5 lb (2.5 kg)

Maximum flow rate

- 40 liters/min. (10.56 gallons/min.) at 60 psi

**Installation Notes**

This product must be installed following the installation instructions provided.

WARRANTY

Kalia Inc. guarantees all aspects of its products to be free of defects in material and workmanship for normal residential use. **Refer to the warranty included with the Kalia products for details.**

Product dimensions:

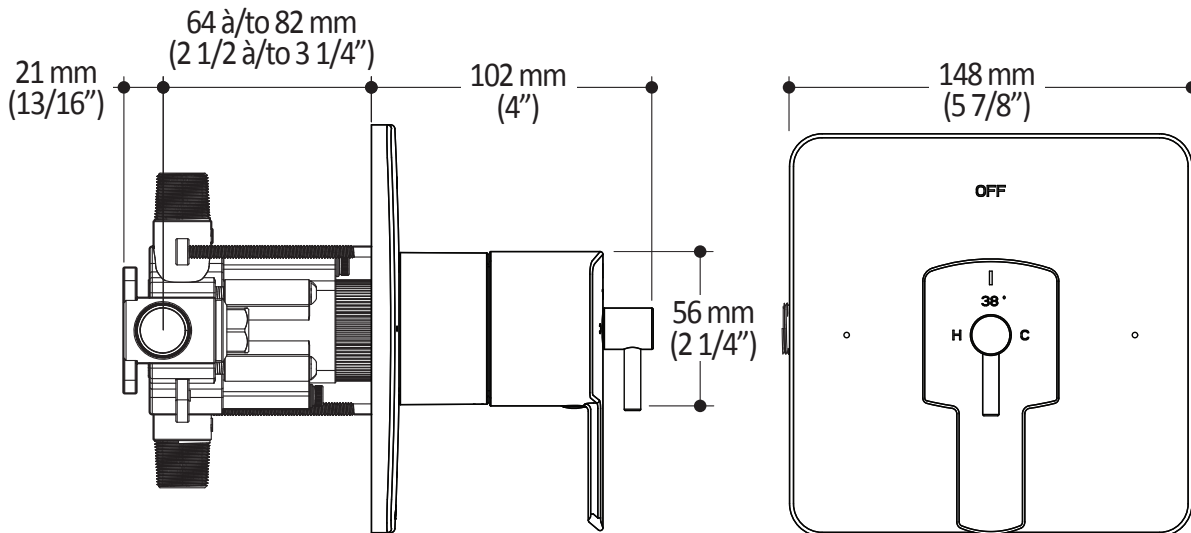

Important: Dimensions are approximated and are subject to changes. Please refer to the installation instructions.

Kalia inc.
1355, 2nd Street
Sainte-Marie (Quebec)
Canada G6E 1G9

t. 1-418-387-9090
1 877 GO KALIA (1-877-465-2542)
f. 1-418-387-9089
www.KaliaStyle.com