

DRINKING FOUNTAIN: KEPAC-SBF-STN

KEPAC-SBF-STN | 2000102864

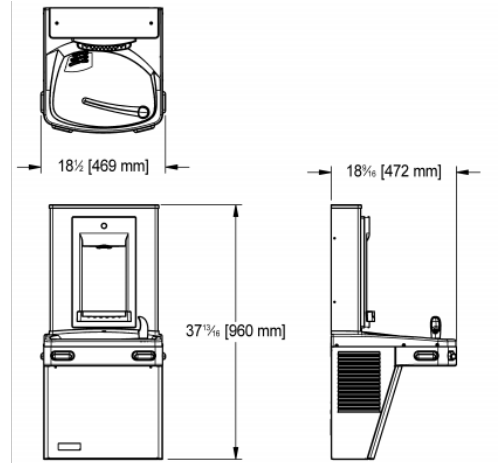

Combination sports bottle filler. Sports bottle filler cabinet finish is brushed stainless steel. Waterways are lead-free in materials and construction. Drinking fountain is mechanically activated. Surface mount frame assembly. Units have built-in 100 micron strainer stops particles before they enter the waterway. One piece stainless steel top. Low flow bubbler with flexible guard. Heavy duty galvanized steel frame. Unit will comply with wheelchair accessibility when properly installed. Manual fountain activation using antimicrobial copper push pads.

Product Certified to NSF/ANSI Standard 61, Annex G (weighted average lead content of $\leq 0.25\%$) and is in compliance with California's Health & Safety Code Section 116875 (commonly known as AB1953). Models covered by this specification comply with all known Plumbing Codes. Listed by Underwriters' Laboratories to U.S. and Canadian standards.

Stainless steel, manually activated bottle filler. Optional filter kit 033926-001.

TECHNICAL DATA

gross weight	19.96 kg
inlet diameter	DN 10
material	STAINLESS-STEEL
material code	1.4301 Chrome Nickel steel V2A
outlet size	DN 32
Overall front to back	18 9/16"
overall height	37 13/16"
Overall left to right	18 7/16"
type of mounting	wall mounting
Cabinet finish	satin finished
net weight	0.00 kg
Wheelchair compliant	yes
Bottle filler	Yes
Type of operation	Manual operation

PROJECT INFORMATION

Item Location _____

Project Number _____

Quote Number _____

Notes _____

Engineer's Approval