

IMPORTANT – LEAVE THESE INSTRUCTIONS WITH THIS UNIT



BOWEN WALL SETS INSTALLATION INSTRUCTIONS FOR RENOVATOR PRODUCTS

PRODUCT	LENGTH	HEIGHT
SIDE WALLS	TOLERANCES $\pm 1/4$" (6 mm)	
5530L/R	25 3/8" (645 mm)	61 1/2" (1562 mm)
25311L/R	24 9/16" (624)	61 3/8 (1559 mm)
BACK WALLS		
5760	57" (1448 mm)	61 1/2" (1562 mm)
25310	59 7/8" (1521 mm)	61 3/8 (1559 mm)

INSTALLATION

1. Once the tub has been installed according to the tub installation instructions, proceed with these wall set installation.
2. Carefully mark the location of the fill spout, shower valve and shower head if they will be mounted in the wall panel. No marking is necessary for the shower head if it is mounted above the wall panel. (Fig. 1)
3. Drill the holes for the fill spout, shower valve and shower head if necessary.
4. Clean any debris from the drilling process.
5. Install the back wall (Fig. 2) and apply a 1/4" bead of Silicon caulking on the back wall flanges. (Fig. 3)
6. Align the holes in the side wall flanges with the four Christmas Tree clips on the back wall flanges. Push the side walls onto the Christmas Tree clips. Some force may be required. (Fig. 3)
7. Ensure gap between back wall and side walls are closed before proceeding with the next step.
8. Secure the flanges to the studs with pan head screws, 8" (203mm) on center. If non-self drilling screws are used, pre-drill pilot holes through the flanges to prevent cracking. (Note: Heads should not protrude too much or the drywall installation may be affected).

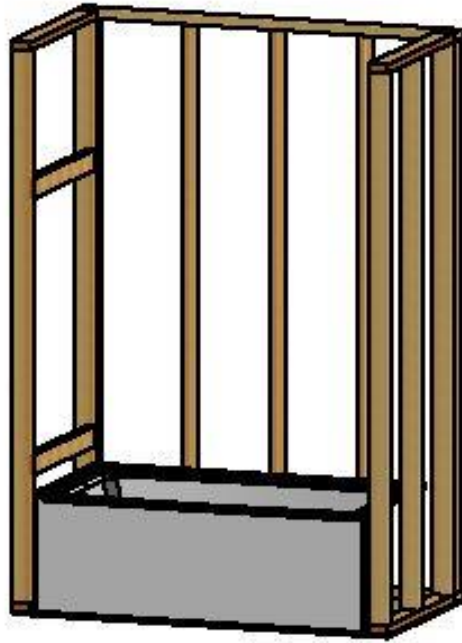

Fig 1

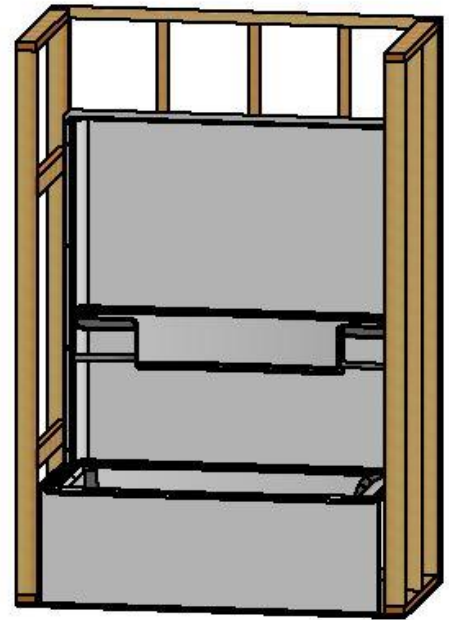

Fig 2

APPLY SILICON ALONG BACK
WALL FLANGES.

PUSH HOLES IN SIDE WALLS
THRU CHRISTMAS TREE CLIPS.

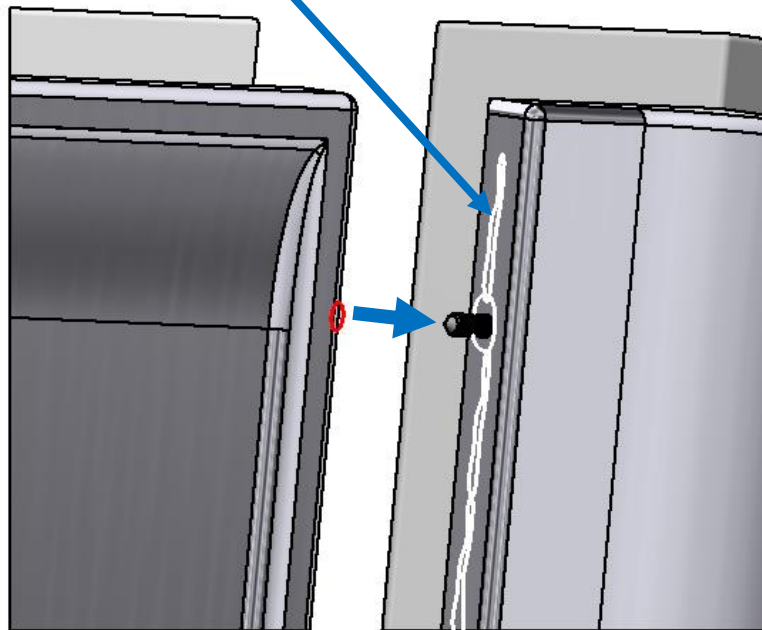

Fig 3

DRYWALL

We offer two suggested methods for drywall installation:

METHOD A: Where tile will be used as the finished surface.

1. Drywall is butted up to the edge of the nailing flanges, and secured to the framing studs.
2. Mud, tape, and finish drywall.
3. Attach tile to the drywall, with the bottom edge of the tile resting on the tile ledge.
4. Seal the joint between the tile and the unit, all the way around the unit, with a silicone or other water-resistant sealant.

METHOD B:

1. Apply furring strips to studs, up to edge of nailing flange.
2. Apply water-resistant sealer to horizontal nailing flange surfaces, then install wall board with factory finished edge (paper bound) 1/4" (6mm) above horizontal ledge. Where practical, wallboard should extend at least one stud beyond unit.
3. Vertical nailing flanges should also be furred, and wallboard embedded in sealing compound.
4. Mud, tape and finish true and level.

FINISH:

1. Caulk all openings around valves and outlets with water-resistant sealant.
2. Install all finished faucet and drain trim, and shower door.
3. Protect finished installation against other construction damage.

Method A

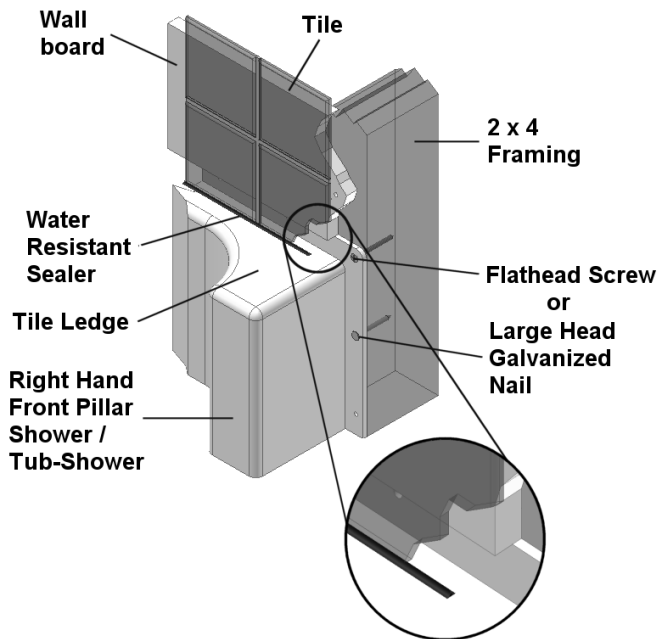

Method B

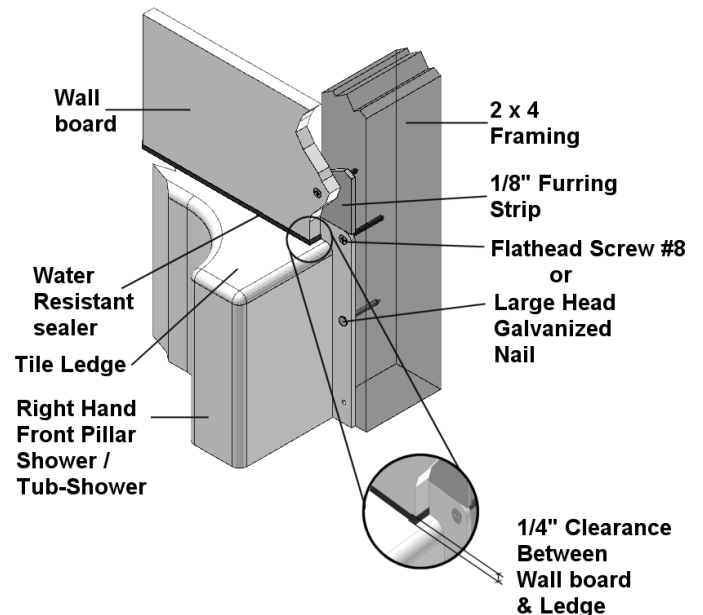

CARE & MAINTENANCE

The following hints on care and maintenance are offered to assist you in keeping your tub or shower in "as new" condition.

Normal Care:

A quick sponge-down with warm water and a liquid detergent such as Mr. Clean, Fantastic, or Lysol Tub and Tile Cleaner will take care of most cleaning needs. In areas where the water is hard, more frequent cleaning will be necessary to avoid a build up on the surface. We recommend that a good quality car or boat wax be applied occasionally – this will preserve the gloss and will make cleaning easier.

Stains:

For stubborn stains, start with a liquid detergent; if this does not work, try a mild powder detergent such as Spic and Span, which also works well for removing heavy soap film. Cleaning pads made of nylon; saran or polyethylene and containing no abrasives may be used. Do not use abrasive scouring powders or metal scouring pads – they can permanently damage the finish.

A mild abrasive action can be accomplished with an automobile type of rubbing compound – there are several types available, both coarse and fine. The fine ones take a little longer to remove a stain, but they do not dull the surface as much.

Dull Areas:

Should your stain removal result in a dull area, the shine can be restored with an automobile cleaner wax, such as Turtle Wax.

Paint Splashes:

A quick wipe with mineral spirits, turpentine or Polyclens and then a wash with water will remove paint. Do not use paint remover or stripper, as these contain solvents, which could permanently damage the surface.

Things to Avoid: Sand and grit. Dropped tools.

Damage:

Should your unit suffer accidental damage, do not despair, as it is quite possible that it can be repaired by a qualified repair person. Consult your plumber, wholesaler or a Hytec Sales Agent.



LIMITED 5 YEAR WARRANTY

All acrylic and gelcoat products manufactured by Hytec are covered by a 5-year warranty from the date of sale to the original owner. This warranty does not cover materials and component parts manufactured by others (such as pumps, jets, pipes, and fittings), which are subject to warranties offered by their original manufacturers. Hytec Plumbing Products warrants to the purchaser of each Hytec product that such product will at time of sale be free from defect in material and workmanship, and that Hytec will at its option repair the original unit or supply an equivalent unit in exchange, such exchange to be F.O.B. at Hytec warehouse. Hytec shall not be responsible for shipping, handling, or installation damage; or any expense of removal, transportation or installation of any original or exchange unit. Under no circumstances will Hytec Plumbing Products assume liability for consequential damages or labour charges resulting therefrom.

This warranty is non-transferable and shall be voided if the unit is removed from its place of initial installation or is not installed in accordance with the manufacturer's instructions. Further, this warranty does not apply if the unit has been subjected to accident, abuse, misuse, damage caused by flood, fire or act of God, or if the unit or the plumbing fixtures used in connection with it are not installed in compliance with local codes and ordinances. Any modifications or alterations to a unit, without prior authorization from Hytec Plumbing Products, or the installation of therapy jets by anyone other than Hytec Plumbing Products, will void all warranties. This includes the installation of steam generators.

HYTEC'S LIMITED WARRANTY OBLIGATIONS ARE EXPRESSLY LIMITED TO THOSE SET FORTH HEREIN, AND ARE IN LIEU OF ALL OTHER WARRANTIES, EXPRESSED OR IMPLIED. THE LIABILITY OF HYTEC TO THE BUYER WITH RESPECT TO THE SALE OF A UNIT SHALL BE LIMITED TO REPAIR OR REPLACEMENT AS PROVIDED HEREIN TO A MAXIMUM OF THE PURCHASE PRICE OF THE RELEVANT UNIT AND DOES NOT INCLUDE ANY COST OF REMOVAL OR REINSTALLATION OR CONSEQUENTIAL DAMAGES OF ANY KIND.

To obtain warranty service, contact Hytec Customer Service at **(800) 871-8311** or **(250) 546-3067**, or email **hytec.customer.service@kohler.com**. Please have ready all pertinent information regarding your claim, including a complete description of the problem, the product, model number, serial number and a copy of your original invoice. If the serial number is not available, please provide a digital photo of the unit.

Authorized Service Representatives for Hytec have been thoroughly trained to perform both in and out of warranty repairs to Hytec products. Through this training, they are familiar with the Hytec Warranty Policy. If in the opinion of the Authorized Service Representative, the service required is not within the scope of the Hytec Warranty Policy, they will advise you before beginning the work. Should this occur, payment of all invoices related to the service is the responsibility of the consumer. If the problem can be attributed to incorrect installation, please contact your installing contractor. Should there be a difference of opinion pertaining to warranty coverage between the Authorized Service Representative and the consumer; clarification will be provided by Hytec Customer Service.

HYTEC PLUMBING PRODUCTS
(Division of Kohler Canada Co.)
4150 Spallumcheen Drive
Armstrong, BC, V0E 1B6
Phone (250) 546-3067 • Fax (250) 546-3170

Please visit our website <http://www.hytec.ca> to find your local representative contact information.