

ECOPOWER® Ultra High-Efficiency Urinal Flush Valve for Reclaimed Water, 0.125 gpf

FEATURES

- 0.125 gpf
- Designed with robust materials necessary for reclaimed water use
- Durable chrome plated body with tamper-proof screws and solid bronze valve body with EPD coating
- Self-powered hydroelectric flush valve system
- No minimum daily usage requirement
- Neutral rough-in and adjustable tail piece connection
- True mechanical flush override
- Smart sensor with self-adjusting detection range
- 6-second detection time to prevent ghost flushing
- Exposed flush valve with 3/4" angle stop and 3/4" vacuum breaker set
- For urinal with 3/4" top spud inlet
- ADA compliant
- May help contribute to LEED V4 points

MODELS

- TEU1UAX12#CP (Top Spud)
 - TEU1UAX#CP (0.125 gpf flush valve)
 - VB0912X#CP (3/4" vacuum breaker tube, 3/4" angle stop)

COLORS/FINISHES

- #CP Polished Chrome

CODES/STANDARDS

- Meets or exceeds 1037/ASME A112.1037/CSA B125.37
- Certifications: IAPMO(cUPC), EPA WaterSense, ASSE, State of Massachusetts, and others
- Code Compliance: UPC, IPC, NSPC, NPC Canada, and others
- Complies with CA Title 20 regulations and CalGreen
- ADA compliant
- Complies with CA Prop 65 warning requirements



CALGreen



PRODUCT SPECIFICATION

TOTO® Model No. _____
 Product shall be 0.125 gpf. Product shall be an automatic infrared sensor-activated, urinal flush valve. Product shall use hydropower, ECOPOWER flush valve system. Product shall have durable chrome plated body with tamper-proof screws and solid bronze valve body. Product shall have neutral rough-in and adjustable tail piece connection. Product shall have smart sensor with self-adjusting detection range. Product shall have true mechanical flush override. Product shall have 6-second detection time with no flush delay. Product shall have solenoid with self-cleaning mechanism. Product shall be ADA compliant.

TEU1UAX

ECOPOWER® Ultra High-Efficiency Urinal Flush Valve for Reclaimed Water, 0.125 gpf

SPECIFICATIONS

Material	Bronze casting
Power Supply	ECOPOWER
Sensor Detection Time	Factory setting at six (6) seconds minimum
Sensor Detection Range	Self-adjusting to environment
Discharge Quantity	Preset to 0.125 gpf / 0.5 lpf
Operating Temperature	32-104°F(0-40°C)
Water Supply Pressure	15 psi - 125 psi*
Water Supply Connection	3/4" NPT
Warranty	Three year limited

*Water pressures over 80 psi are not recommended for most plumbing fixtures. Check your local plumbing code for details.

DIMENSIONS

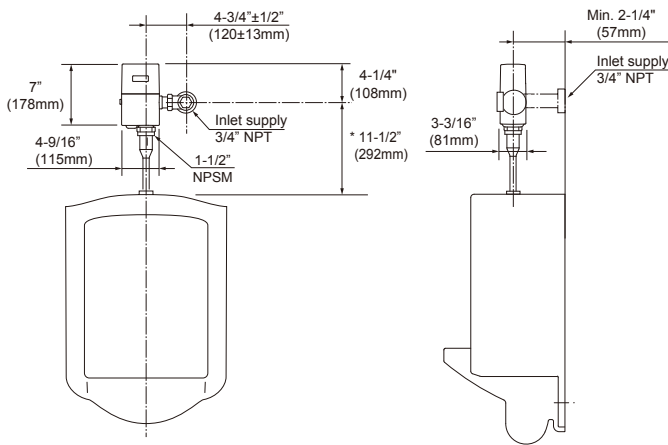
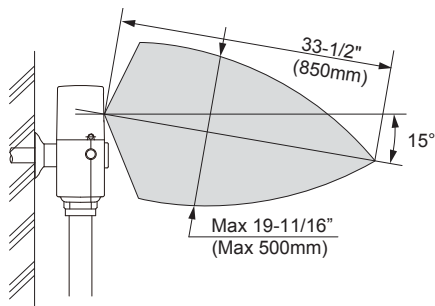

* Check local codes

INSTALLATION NOTES

RECLAIMED WATER QUALITY PARAMETERS	
Chloride Ion Concentration	< 600mg/L
pH	5.8~8.6
Free Carbonate	< 50mg/L
Langelier's Index	> -3.00
Nitrate Ion Concentration	< 60mg/L
Conductivity	< 250mS/m
Sulfate Ion Concentration	< 100mg/L
Residual Chlorine Concentration	< 2mg/L
Hydrogen Sulfide Gas	None Existence
Suspended Solids	< 5mg/L

TOTO Reclaimed Water flush valves are designed to perform best when used with TOTO Reclaimed Water urinals/toilets and components. Although TOTO Reclaimed Water products may be used in combination with other reclaimed water product brands, optimal performance might be impaired and attempted use with any non-compliant reclaimed water product(s) could result in corrosion, leakage or void the warranty.

For commercial applications only. Product designed for reclaimed water use (with parameters specified above).

Warning: Adjust control stop for proper flow rate to the fixture. Failure to properly adjust angle stop to the appropriate level can potentially cause property damage.

For detailed installation instructions, please refer to the installation manual. Confirm with local codes and standards for floor drain requirement.

Max flow rate to be used with TEU1UAX _____: 0.125 gpf

TOTO®

These dimensions and specifications are subject to change without notice