



Rinnai Overview

Rinnai Corporation

Rinnai

Rinnai Global



- Based in Nagoya, Japan
- Established in 1920
- 12,000 employees worldwide
- Operations in 13 countries
- One of the world's largest gas appliance manufacturers
- Largest share of the Japanese markets
- The number-one selling brand of tankless gas water heater in North America

- The Leader in Gas Technology throughout the world
- Extensive product offerings of water heaters, boilers, furnaces, cooking products and dryers
- Consolidated turnover: approximately \$3.8 Billion

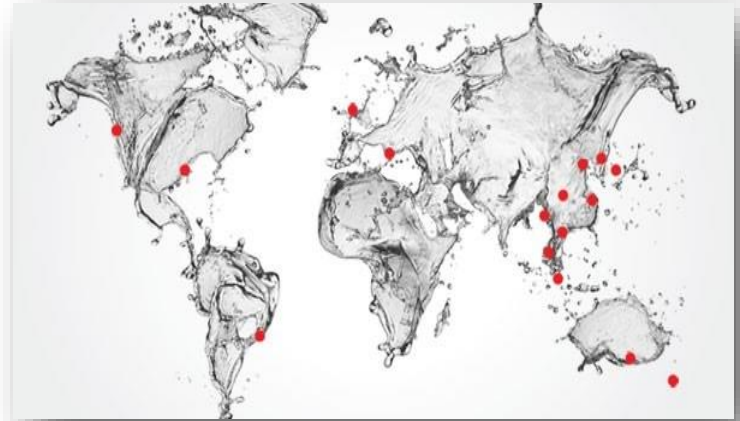

Rinnai North America

- Rinnai North America Headquarters is located in Peachtree City, GA
- Over 385 employees throughout North America
- Rinnai distribution centers are located in Peachtree City, GA and Reno, NV
- Recently tripled the size of Corporate Headquarters to facilitate growth in North America
- Development of state-of-the-art Innovation Center to facilitate new product development



1st To Manufacture TWHs in North America



300,000 square foot state-of-the-art facility in Griffin, Georgia

Canadian Content

- \$40 Million sales annually
- 17 factory direct sales and technical team
- Continued substantial investment in Canada 2024/2025
- Current distribution partners
 - * Andrew Sheret *BA Robinson (West)
 - * Master * Dakin (National)
 - * Deschenes Group * Trent Metals * LK Metal (East)

Rinnai Tankless Water Heaters



SENSEI™

THE **NEXT GENERATION** IN TANKLESS WATER HEATING

Key Product Advantages

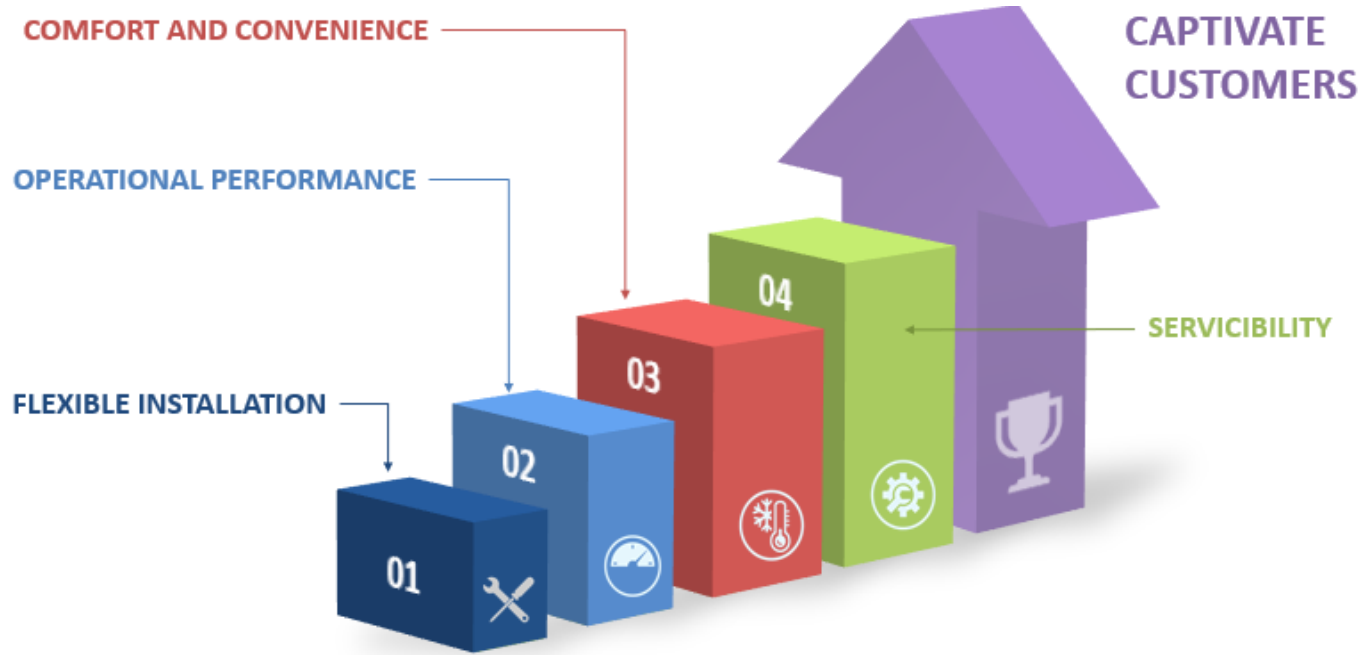

SENSEI Series Features



- All of the key components are designed and manufactured by Rinnai – Vertically integrated to ensure Rinnai quality
- A combustion design combines several components that work in harmony for enhanced system features. These allow for:
 - Easier and more flexible installations
 - In more locations
 - With better operational performance

SENSEI® RX Series

Product Introduction

3/13/2024

Rinnai Corporation



Rinnai

Web Page Content <https://www.rinnai.ca/>

PROs: “The Best to Sell, Install and Service”

SENSEI[®] RX
S E R I E S
Built for the PRO, by the PRO

Refined Sensei RX product line with new innovate features focused towards the Pros for faster installation, serviceability and troubleshooting.

Built for the PRO, by the PRO

SENSEI RX is the best performing condensing tankless water heater Rinnai has ever made.



The highest UEF we've ever reached and an industry first!

Backed by our 15-5-5 Warranty!



15 Years on the Heat Exchanger
5 Years on Parts
5 Years on Labor*
*Requires product to be registered within 90 days of installation or Labor Warranty defaults to 1-year.



Superior Performance, Superior Components

NEW

Improved Turbo Fan™

Enables longer vent runs and flexible vent options
Industry leading 75 feet with 2 1/4" concentric and 2" PVC/CPVC/PP. Up to 150 feet with 3 1/5" concentric and 3" PVC/CPVC/PP.

NEW

Enhanced Primary & Secondary Heat Exchangers

More efficient heat transfer and improved robust design with minimal joints. The tube design is 444 Stainless Steel to provide added durability and heat resistance.

NEW

4-Speed DC Recirculation Pump

Quieter operation in a compact size with higher head pressure for improved performance.

NEW

Retro-fit Internal Pump Kit (RX2RXPCCK)

Adds Rinnai's advanced recirculation capability to non-pump models.

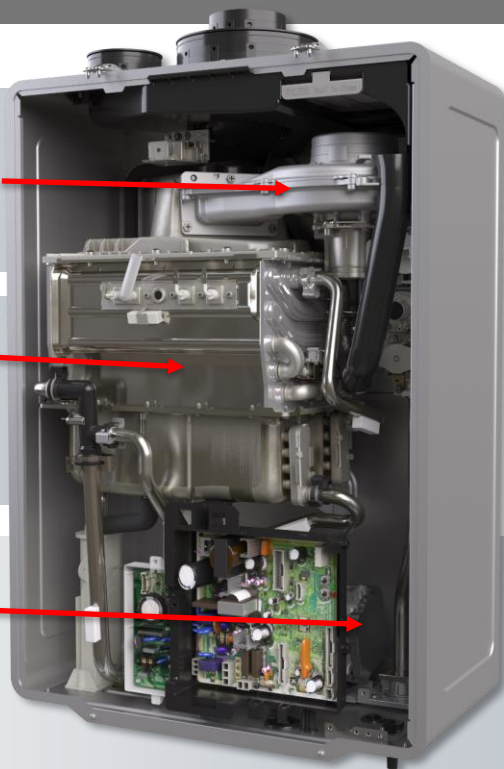

NEW Weighs 58 lbs. 10 lbs. lighter than previous models.

SENSEI[®] RX

SERIES

Built for the PRO, by the PRO



Smart Sense™

NEW

SMART SENSE™

Rinnai's proprietary Adaptive Gas Valve Technology adjusts to either Natural Gas or Liquid Propane Gas for optimal combustion - **no conversion kit required.**



- Allows Natural Gas unit to be converted to Propane with a parameter change on the controller. No Orifice change needed.
- Innovative Gas Sensing technology monitors variation in gas heating values to optimize combustion.
- Propane Rating label included in the box for Propane conversions.
- Gas conversion possible without opening the front cover.

Smart Connect™

NEW



SMART➤CONNECT™

Allows you to connect your smart phone or tablet to the SENSEI® RX Series via Bluetooth®. Use the Rinnai Central™ App for quick, simplified tankless water heater set-up and registration, significantly reducing your install time.

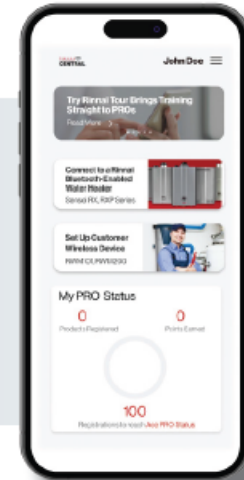

- The new Rinnai Central App combined as one app for Pro and homeowners with 2 levels of login credentials.
- Pros can leverage the Bluetooth capability to install, troubleshoot and service the new Sensei RX product.
- Installation and set-up can be done via Bluetooth
- Pro have the options to use Simplified or Advanced setup wizard in the app to customize setup adding repeatability and driving time savings with installations.
- Quick product registration now possible during setup process.

Convenient Set-up and Registration

Initiate Set-up (WiFi not required)

Push the  **Bluetooth**[®] button on the tankless controller with the Rinnai Central[™] app open to

to **SMART CONNECT**[™]



Use the **Quick Set-Up** screen for speedy unit configuration.

Use **PRO-files**[™] to pre-load and save all parameter settings in app for future installs.

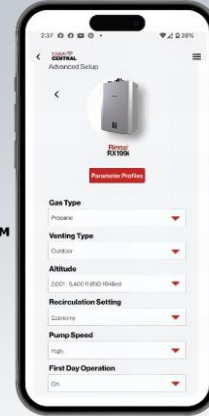

Fuel Type
SMART SENSE[™] lets you select the fuel source without removing the cover!

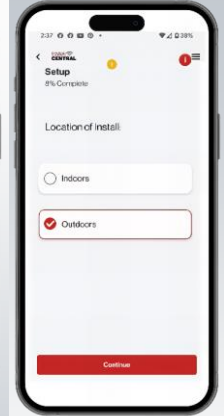

Indoors / Outdoors
VERSA-VENT[™] cap allows any unit to install outdoors (purchased separately)

Quick Flush™

NEW

QUICK FLUSH™

Provides a more efficient flushing procedure to make periodic preventive maintenance a simple task to perform.



- New routine added to flush Sensei RX units.
- New LC error code identifies need for flushing.
- Quick Flush Routine provides 60-minute count down timer to flush unit.
- Unit automatically manages valves within the unit when in quick flush routine to flush all water passages.
- Captures flushing history – can be viewed on the app with other error code history on the unit.
- Product can be set to Descaling mode (dES) with a press of a button on the Control board.

Product line up

Sensei-X RX/CX Series Condensing Tankless Water Heater

Residential	
Without Pump	With PUMP
RX199iN	RXP199iN
RX180iN	RXP160iN
RX160iN	
RX130iN	

Commercial	
Without Pump	With PUMP
CX199iN	CXP199iN
CX160iN	CXP160iN

- IDENTICAL to current Sensei in terms of BTU
- Only indoor natural gas version offered with new Sensei RX.
- 6 Residential and 4 Commercial SKUs
- Consolidate 24 SKUs on current Sensei Residential to 4 SKUs
- Consolidate 8 SKUs on current Sensei Commercial to 2 SKUs
- 2 new with pump models added to Sensei CX Commercial offerings



Sensei to Sensei RX SKU comparison

**REDUCE
YOUR SKUs
from
24 MODELS
to 6!**

**REDUCE
YOUR SKUs
from
24 MODELS
to 6!**

		SENSEI® Indoor/Outdoor Natural Gas/Propane		NEW SENSEI® RX / RXP Default is Indoor Natural Gas Only. Unit can be modified to Outdoor and Propane (see details below).						
		Current	Max KBTU	NEW	MAX KBTU	UEF	Included in the Box	Propane Conversion	Outdoor Conversion	Accessories (Sold Separately) NEW*
RESIDENTIAL (RX/RXP)	No Built-in Pump	RU199iN RU199iP RU199eN RU199eP	199	RX199iN	199	0.98	<ul style="list-style-type: none"> • Sensei RX/RXP Water Heater • Wall Mounting Bracket • 4-Self Tapping Screws (4.2X25MM) • Gas Conversion label (Propane) • 2-Vent Screens • 2-Vent Screws • Installation and Operation Manual • Wall mounting Bracket Template 	<ul style="list-style-type: none"> • Field Convertible to Propane • Leverages Smart -Sense™ Adaptive Gas Valve built in the unit • No Conversion kit needed. 	Use Outdoor Versa-Vent™ Vent Cap (RXOVC) Sold separately	<ul style="list-style-type: none"> • Isolation Valves with PRV (MIVK-T-LW) • Outdoor Vent Cap (RXOVC)* • Internal add-on recirc. pump conversion Kit (RX2RXPCK)* • Dedicated return with isolation valves and PRV (107000639)* • Pipe Cover (PCD11-SHS)* • Recess Box (RGBCTWHRX)* • Retrofit Door for RX/CX in RGB-CTWH-4 (104000335)* • Retrofit Door for RX/CX in RGB-CTWH-3,2,1 (104000336)* • Leak Detection Kit (RXLeakKit)* • Bottom plate for Pipe Cover (109001364)* • Recirculation Push Button (RPB200)* • Rinnai Wireless Module (RWM200)* • EZConnect Cable (REU-EZC-3)* • Gas conversion kit (Rating Plate Labels only) (104000330)* • Controllers- MC-601-BK/W, MC-195T-US • Condensate Neutralizer (804000074) • Scale Cutter (103000038), Scale Cutter Refill (103000039) • OPU Switch (REU-OPU3)
		RU180iN RU180iP RU180eN RU180eP	180	RX180iN	180	0.98				
		RU160iN RU160iP RU160eN RU160eP	160	RX160iN	160	0.97				
		RU130iN RU130iP RU130eN RU130eP	130	RX130iN	130	0.97				
	Recirculation with Built-in Pump	RSC199iN RSC199iP RSC199eN RSC199eP	199	RXP199iN	199	0.98	All items listed above and 1-Thermal Bypass Valve (Cross-over valve)	<ul style="list-style-type: none"> • Propane gas rating label provided with the unit 		
		RSC160iN RSC160iP RSC160eN RSC160eP	160	RXP160iN	160	0.97				

*New for SENSEI® RX/CX Series Water Heaters

Sensei to Sensei CX SKU comparison

**REDUCE
YOUR
SKUs from
8 MODELS
TO 4!**

		SENSEI® Indoor / Outdoor Natural Gas /Propane		NEW SENSEI® CX / CXP Default is Indoor Natural Gas Only. Unit can be converted to Outdoor and Propane (see details below).						
		Current	Max KBTU	NEW	MAX KBTU	Efficiency	Included in the Box	Propane Conversion	Outdoor Conversion	Accessories (Sold Separately) NEW*
COMMERCIAL (CX/CXP)	No Built-in Pump	CU199iN CU199iP CU199eN CU199eP	199	CX199iN	199	UEF: 0.98 TE: 0.97	<ul style="list-style-type: none"> Sensei CX/CXP Water Heater 	<ul style="list-style-type: none"> Field Convertible to Propane Leverages Smart -Sense™ Adaptive Gas Valve built in the unit. No Conversion kit needed Propane gas rating label provided with the unit 	Use Outdoor Versa-Vent™ Vent Cap (RXOVC) Sold separately	<ul style="list-style-type: none"> Isolation Valves with PRV (MIVK-T-LW) Outdoor Vent Cap (RXOVC)* Internal add-on recirc. pump conversion Kit (RX2RXPCCK)* Dedicated return with isolation valves and PRV (107000639)* Pipe Cover (PCD11-IB)* Recess Box (RGBCTWHRX)* Retrofit Door for RX/CX in RGB-CTWH-4 (104000335)* Retrofit Door for RX/CX in RGB-CTWH-3,21 (104000336)* Leak Detection Kit (RXLeakKit)* Bottom plate for Pipe Cover (109001364)* Recirculation Push Button (RPB200)* Rinnai Wireless Module (RWM200)* Gas Conversion Kit (Rating Plate Labels only) (104000330)* Controllers- MC-601-BK/W, MC-195T-US Condensate Neutralizer: (103000067/804000074) Scale Cutter (103000038), Scale Cutter Refill (103000039) OPU Switch (REU-OPU3) Cascade Cable (REU-CSA-C1 and REU-CSA-C2) Recirculation Pump (GTK03U)
		CU160iN CU160iP CU160eN CU160eP	160	CX160iN	160	UEF: 0.97 TE: 0.97	<ul style="list-style-type: none"> Wall Mounting Bracket 4-Self Tapping Screws (4.2X25MM) 			
	Recirculation with Built-in Pump			CXP199iN	199	UEF: 0.98 TE: 0.97	<ul style="list-style-type: none"> Gas Conversion label (Propane) 2-Vent Screens 2-Vent Screws 			
				CXP160iN	160	UEF: 0.97 TE: 0.97	<ul style="list-style-type: none"> Installation and Operation Manual Wall mounting Bracket Template 			

RX Product

- Accepting orders February 1st, 2024
- First ship date is March 1st, 2024

Rinnai Home Heating Solutions

Rinnai Heating Products

EnergySaver® Direct Vent Wall Furnace



Direct Vent Wall Furnaces

- Self-adjusting heat that keeps room temperature consistent, from floor to ceiling.
- Save energy – and money: Rinnai's unique modulating technology produces the specific level of heat needed.
- The easy-to-use programmable thermostat; Set your heater to operate at a comfortable temperature while your home, then automatically adjust to a lower setting when you're gone.
- Customized comfort: Tailor supplemental or zone heating to your usage, habits and needs, for the most comfort in the most efficient way.
- Fast installation: No ductwork means quicker installation



Rinnai Air Handler



- Available in multiple sizes
- Available with or without a pump
- Multiple configurations
- Domestic Hot Water (DHW) priority
- Anti-stagnation built in
- Multiple A/C coils approved
- Matched with Rinnai
 - Tankless Water Heater OR
 - I Series Boiler

I-Series Boiler

Key Product Advantages



North America

- Designed for North American Needs
- Combines Rinnai Global Technologies and Best Practices
- Same Rinnai Quality and Reliability



I-Series Boiler



Designed for the homeowner with the following three key benefits vs competition:

- Ability for simultaneous usage of central heat and domestic hot water
- More precise control of domestic hot water temperature
- Multi-zone heat control

I-SERIES PLUS™



CREATING A HEALTHIER WAY OF LIVING

I Series Plus Solo and Combi Boiler Features

NEW Advanced Controls with Improved Front Panel

NEW 7 Heating Reset Curves

NEW Smart Sense™ Adaptive Gas Valve Technology

NEW 4 Built-In Zones for better comfort levels

NEW Cascade capability:

- 1 combi unit and up to 23 tankless units
- Up to 24 solo boilers

NEW Smart Connect™ Bluetooth Enabled Quick Set-up

NEW Air Handler Connectivity

Low NOx Emissions ($\leq 20\text{ppm}$)

Warranty:

Item	Residential Applications	Commercial Applications
Heat Exchanger	12 Years	5 Years
All Other Parts and Components*	5 Years	5 Years
Reasonable Labor	1 Year	1 Year



I Series Plus Solo and Combi Boiler Features

- ❑ High Efficiency **up to 96% AFUE**
- ❑ More Sizes to Match Heating/DHW Requirements
 - 60MBH-199MBH
- ❑ TDR – up to 10:1 Heating and up to 13.3:1 DHW
- ❑ Venting
 - **NEW** 2" up to 75 ft and 3" up to 160 ft
 - PVC, CPVC, PP and SS Venting Materials
 - **NEW** Common Venting up to 8 units
 - All Venting Configurations
- ❑ High Altitude Approved up to 10,100 ft.



I Series Plus Solo and Combi Boiler Models

Combi Models			
RAC Part Numbers	New or Upgrade	Heating Input MBH	DWH Input MBH
IP199199CN	New	199	199
IP175199CN	New	175	199
IP150199CN	New	150	199
IP120199CN	Upgrade	120	199
IP090199CN	New	90	199
IP090160CN	Upgrade	90	160
IP090099CN	New (Canada)	90	99
IP060160CN	Upgrade	60	160

Solo (Heat Only) Models		
RAC Part Numbers	New or Upgrade	Heating Input MBH
IP199SN	New	199
IP175SN	New	175
IP150SN	Upgrade	150
IP120SN	Upgrade	120
IP090SN	Upgrade	90
IP060SN	Upgrade	60

} New HX

Full product range: 14 models (up from 7)

Upgrades:

- New PCB – 4 zones, 0-10V, AH connection, and cascading
- Gas valve
- Front panel
- Pressure sensor
- Additional flame rod

I series Plus Product

- Accepting orders June 1st, 2024
- First ship date below 150 MBH is July 1st, 2024
- First ship date above 150 MBH is August 1st, 2024

Commercial Products



The Rinnai Commercial Advantage

Rinnai Corporation

Rinnai

Rinnai Commercial Product Portfolio



CX Commercial Tankless

- 0.98 UEF / 97% TE
- Cascade Controls
- Pump and Non-Pump Models
- Brass Internal connections



Demand Duo H Series

- Integrated Pump Controller
- Overshoot Logic
- Dual Pumps DD2
- ASME variations



Demand Duo R Series

- Integrated Pump Controller
- Overshoot Logic
- Dip Tube tank
- Vent Transition



Tankless Rack Systems

- Aluminum Wall Racks
- Multi-pump CXP models
- Includes Valve Kit

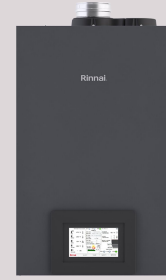

Commercial Boiler

- 97% TE / SS HEX
- 7" Color LCD
- Common Vent
- Cascade Controls
- Wi-Fi and BMS

New CX Commercial Tankless

- High Temperature up to 185°F
- Integrated Cascade Controls
- Brass Internal Fittings
- Integrated Pump Models **(New)**
- Cascade Pump Models **(New)**



Demand Duo H Series: Single

- **Easy Installation**
- **Integrated Pump Controller (New)**
- **Improved Recovery Performance**
- **Low Total Cost of Ownership**
- **6 Year tank warranty**



Demand Duo H Series: Double

- **Easy Installation**
- **Horizontal and Vertical Options**
- **ASME and Non-ASME tanks**
- **Dual Pumps & Controls (New)**
- **6 Year Tank Warranty**



Demand Duo R Series

- **Direct Replacement for Atmospheric Tanks**
- **Utilize Category 1 Vent**
- **Easy Installation**
- **Integrated Pump Controller (New)**
- **Improved Recovery Performance**
- **6 Year tank warranty**



TRS Tankless Rack Systems

- Free standing rack system
- 2-6 units
- NG or LP
- Outdoor convertible with Versa Vent (New)



TRW Tankless Rack Systems

- **Wall Hanging Rack System**
- **2-3 units**
- **NG or LP**
- **Outdoor convertible with Versa Vent**
- **Pump Models Available (New)**



TRX Tankless Rack Systems

- **Wall hanging rack system**
- **Convertible to Free Standing Rack with Leg Kit**
- **Perfect Rack for Distribution - Fits 3 units per pallet**

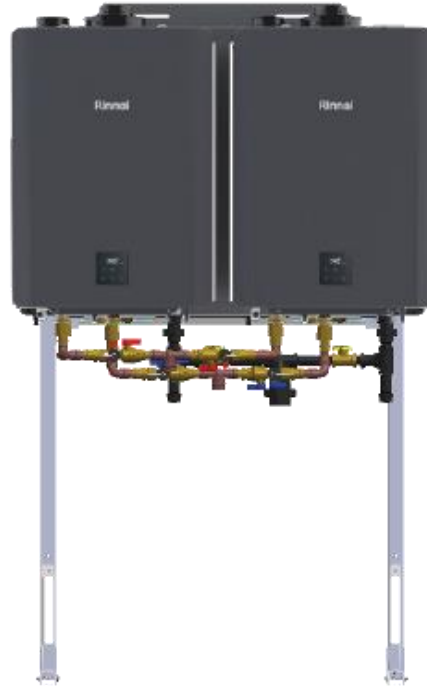

CX and related Product

- Accepting orders March 1st, 2024
- First ship date is April 1st, 2024

Commercial Heating



Commercial Boiler

RCB • SERIES™

- High Efficiency Stainless HEX
- Light Weight
- LCD controls
- Wi-Fi & BMS Connectivity
- Cascade & Common Vent
- 10 Year Warranty



Efficient and Compact Design

- **SS Water Tube HEX**
- **ASME H stamp**
- **97% Thermal Efficiency**
- **10:1 Turndown Ratio**
- **Hydroformed coil**
 - **Maximizes Thermal Efficiency**
 - **Minimizes Size and Weight**
- **Ultra Low NOx Emission**
- **10 Year HEX warranty**

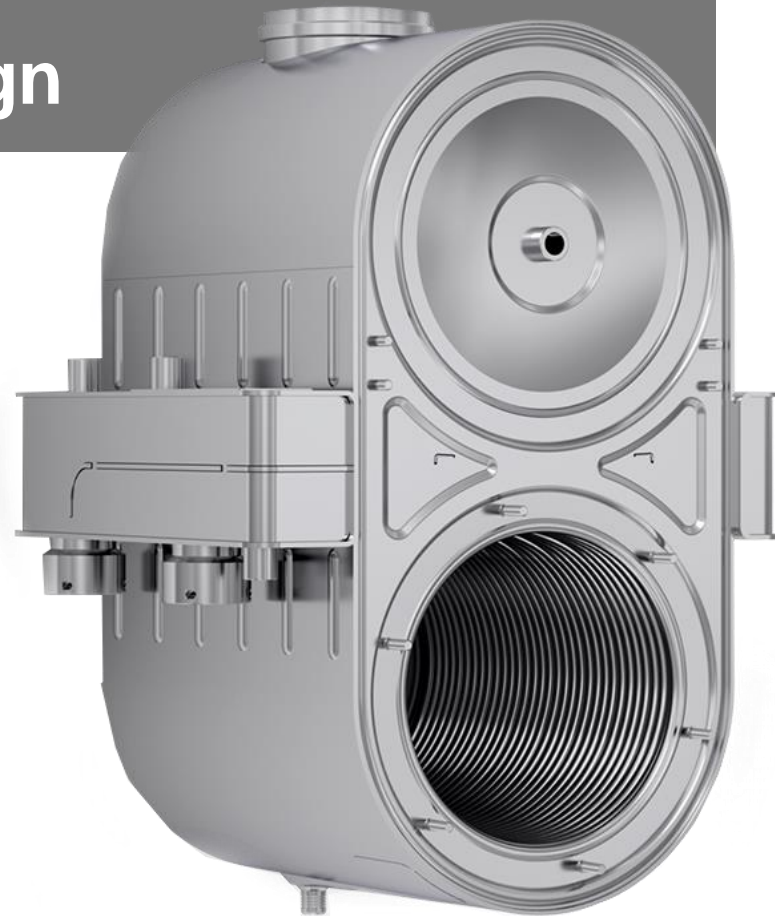

LCD Controls

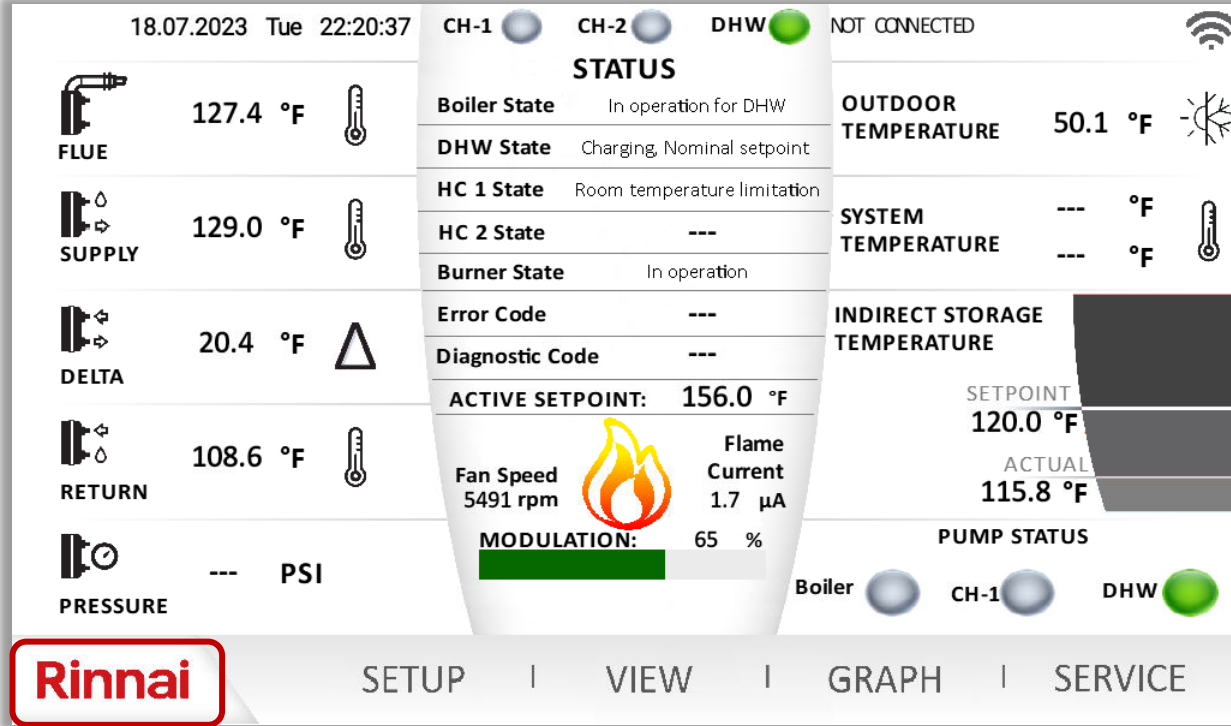

- 7" LCD Touch Screen
- Easy to read features and function
- Home Screen provides basic boiler operation data

LCD Controls; Graph

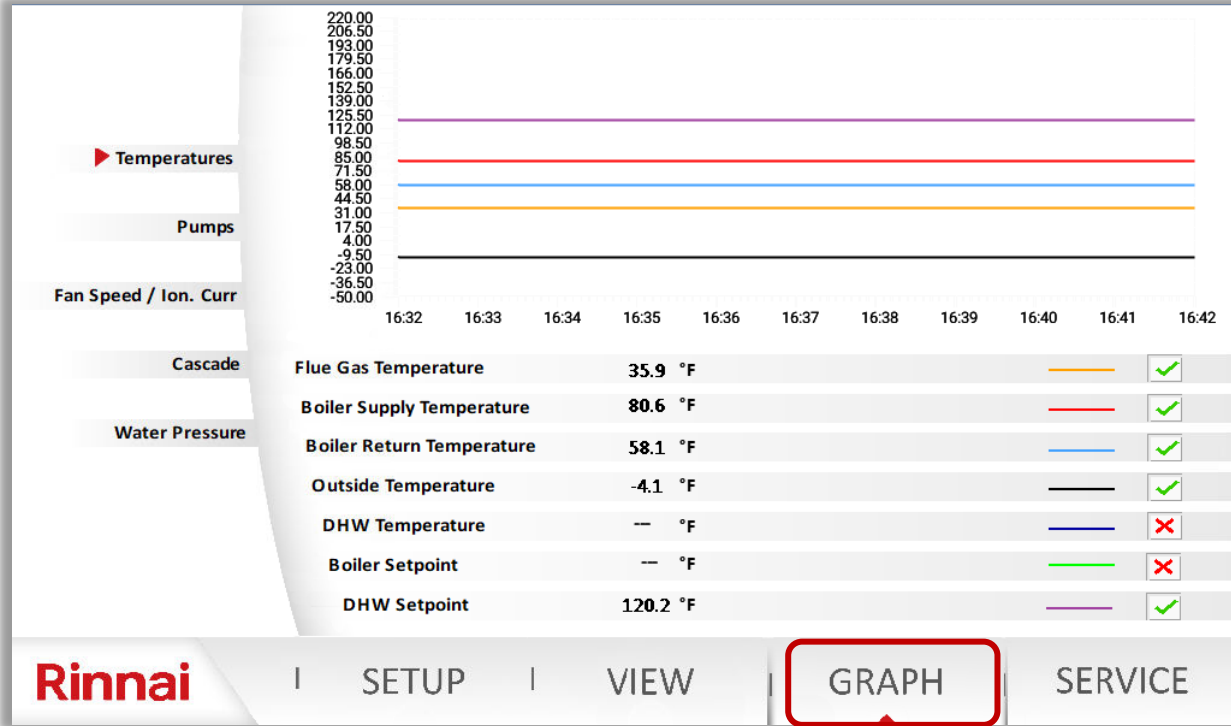

- Real time monitoring on system information

Rinnai

SETUP

VIEW

GRAPH

SERVICE

Connectivity



Venting

Direct Vent



Room Air

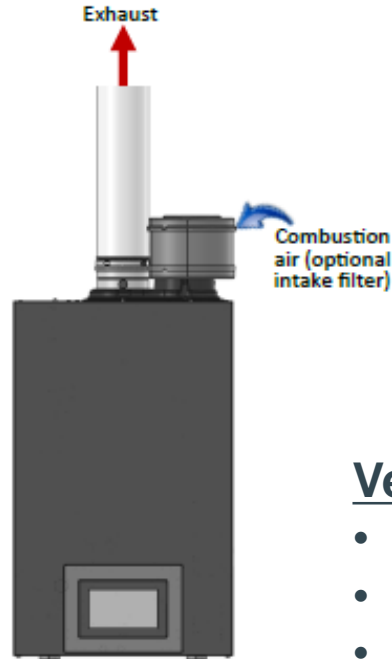

Common Vent; Up to 4 units

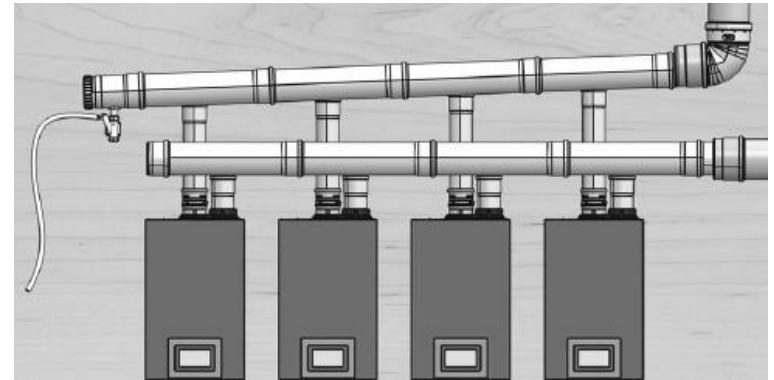

Venting Materials

- PP / PPS
- PVC / CPVC
- Stainless Steel

Venting Manufactures

- Centrotherm
- IPEX
- ECCO
- Duravent

Commercial Boiler Accessories

Included

Wall mount bracket

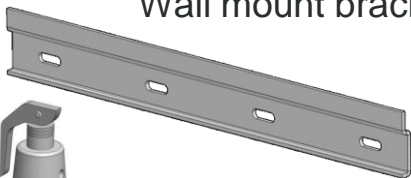

75 PSI PRV

Outdoor
Sensor



2 each spare
6.3A fuses

- Vent screws
- Manual
- User Manual

CREATING A HEALTHIER WAY OF LIVING

Optional



Cat IV Air Inlet Filter
Part: 803000050

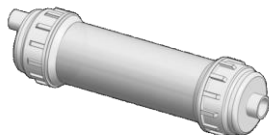

Condensate Neutralizer
Part: 804000074



Cascade System Supply Sensor
(required to cascade)
Part: 803000051

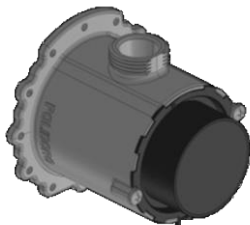

Gas Conversion Kit
301 LP: 803000048
399 LP: 803000049

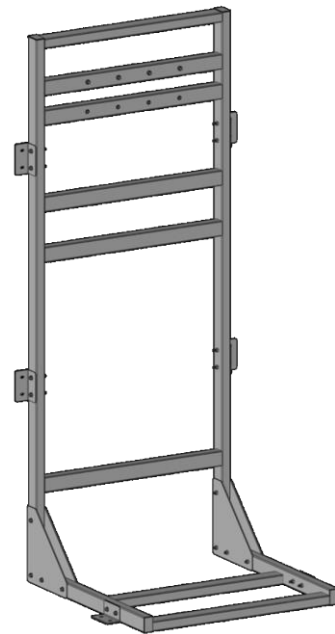

Boiler Rack
Part: 803000047

Warranty

Warranty is
Not
Prorated!

Product Warranty

Description	Commercial
Primary Heat Exchanger	10 YRS
Boiler Parts	1 YRS
Labor	1 YR

Warranty covers:

Defects in materials/workmanship

Indoor installations installed per the manual and all applicable code

Warranty DOES NOT cover failure due to:

Accident, abuse/misuse, alteration/misapplication

Improper Installation/Maintenance/Commissioning

Poor water quality, scale issues, freezing

Please refer to the Manual for full warranty details and guidelines

RCB Product

- Accepting orders NOW
- Shipping immediately

Demand Duo™ 119 Gallon & 80 Gallon

**Part
tank**

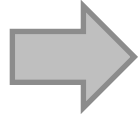

- Durable, energy-efficient 119-gallon storage tank
- Ideal for planned or emergency replacement situations
- Offers more water heating capacity than a traditional tank (315 gallons 1st hour delivery)
- A direct replacement solution with connections similar to most high-efficiency tanks
- Efficient tank recovery methods deliver consistent hot water even during reheat cycles



**Part
tankless**

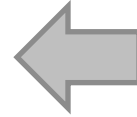

- Fueled by either natural gas or propane
- Keeps pace with demand, from brief, high-spike draws to a supply that's ready to go the distance, day in and day out
- Commercial ENERGY STAR® certified with 98% thermal efficiency (CX199)
- As the heat source, the Rinnai CX199 tankless unit eliminates thermal stress on the tank – lengthening the life of the unit
- Easy, cost-effective maintenance with readily available parts

Demand Duo™ - How It Works

HE Commercial Water heater

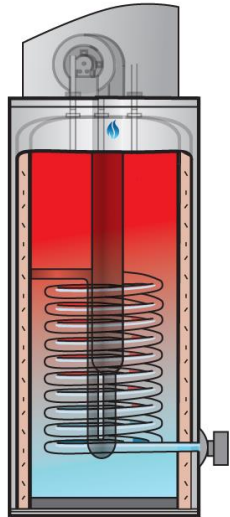

Rinnai Demand Duo Hybrid Commercial Water Heater

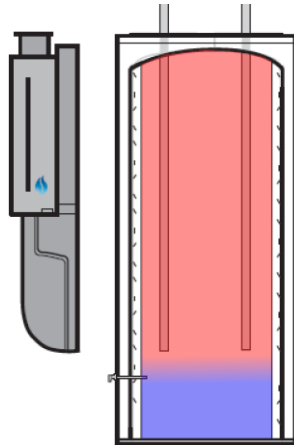

Water Heating Takes place outside the tank for which allows for increased Temperature Stability

Benefits:

1. Reduced Thermal Stress on the Tank
2. Easily replaced components
3. More Hot Water Capacity
4. Consistent Hot Water Temperature

The Demand Duo™ Value Proposition

Heating occurs in the tankless heat exchanger – not the tank

Set-point temperature water delivered to the tank

Removes stress from tank

Extends the life of the product

RESULT = 2x warranty (8 years HEX / 6 years Tank)



So, would you rather replace this at ~\$12,000





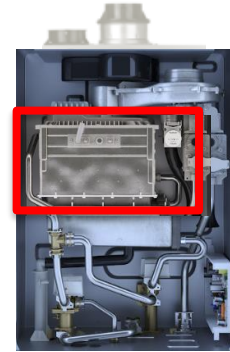





Or this at ~\$800?



2x warranty – similar cost - repair vs replace = lower cost of ownership

Demand Duo™ Commercial Family of Products

CONDENSING COMMERCIAL HYBRID WATER HEATING SYSTEM SPECIFICATIONS

MODELS	DEMAND DUO™ 2 / 119 GAL				DEMAND DUO™ 119 GAL		DEMAND DUO™ 80GAL		
									
Model	CHS398100H	CHS398100HV	CHS398100HVA**	CHS320100HV	CHS199100H	CHS160100H	CHS19980H	CHS16080H	CHS13080H
Part Number	CHS398100HIN/ CHS398100HIP	CHS398100HVIN/ CHS398100HVIP	CHS398100HVAIN/ CHS398100HVAIP	CHS320100HIN/ CHS320100HIP	CHS199100HIN/ CHS199100HIP	CHS160100HIN/ CHS160100HIP	CHS19980HIN/ CHS19980HIP	CHS16080HIN/ CHS16080HIP	*CHS13080HIN/ CHS13080HIP
Dimensions - w x h x d Inches (mm)	38.8 x 68.9 x 44.3 (985.5 x 1750 x 1125.2)	32.9 x 78.9 x 40.2 (835.6 x 2004 x 1021)			32.9 x 78.9 x 40.2 (835.6 x 2004 x 1021)		27.8 x 64.7 x 36.2 (706.1 x 1643.3 x 919.5)		
Product Weight (lbs/kg)	530 / 240	515 / 234	515 / 234	515 / 234	431 / 195	431 / 195	307 / 139	307 / 139	307 / 139
Installation Type	Indoor				Indoor				
Storage Tank	119 Gallons				119 Gallons		80 Gallons		
Min/Max Input (1,000 Btu/h)	15 / 398	15 / 398	15 / 398	15 / 320	15 / 199	15 / 160	15 / 199	15 / 160	15 / 130

New in 2024

Electric HPWH



Rinnai Corporation

Rinnai

Fastest growing category ready to take off

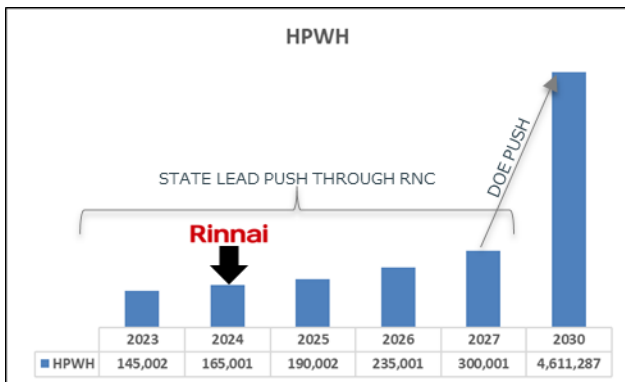

	Overall	RNC Market	R&R Market
CAGR (2018-22)	14%	9%	16%
CAGR (2023-27)	16%	18%	16%

- RNC CAGR stays very strong over the next 5 yrs. as code change impact goes in effect in California, upcoming changes in NY and other large NE cities
- Huge growth opportunity in R&R segment in major electric states with up to \$2,000 IRA federal tax rebate

HPWH SOLD ACROSS ALL CLIMATE ZONES

Region	States	2022 Sales Volume	2023 Sales Volume	2023 % of US total sales Volume	2024 Sales Volume (forecast)
New England	CT, ME, MA, NH, RI, VT	27,926	33,916	22%	41,196
Pacific	AK, OR, WA	18,801	22,505	15%	26,941
Middle Atlantic	NJ, NY, PA	11,122	13,495	9%	16,377
NE Central	IL, IN, MI, OH, WI	7,293	8,558	6%	10,051
Mountain	ID, MT, NV, NM, UT, WY	6,901	8,084	5%	9,486
West North Central	IA, KS, MN, MO, NE, ND, SD	5,699	6,541	4%	7,516

- Cold climate region contributed to 61% HPWH sales in 2023
- Primary reason: quick payback against Electric or Oil water heaters
- Florida remains #1 state with 23K units sold in 2023, followed by WA & CA

Features & Benefits

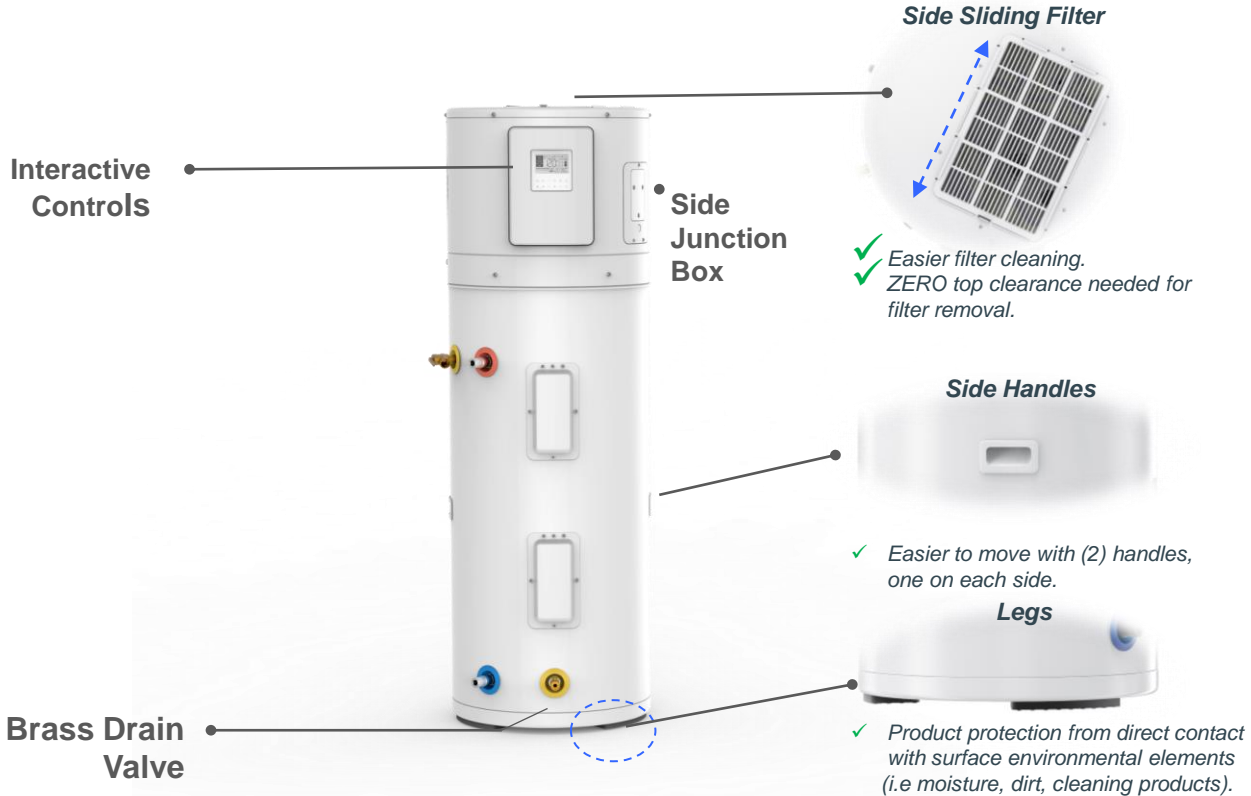

Rinnai Product Performance

	50 Gallon	80 Gallon	Market Comparison
UEF	✓ 3.75	✓ 4.0	exceeds market
CCE	3.0	3.2	exceeds market
FHR	✓ 68	✓ 88	exceed market
NEEA Tier	✓ 4	✓ 4	exceed market
Controls	Interactive LED Screen	Interactive LED Screen	exceed market
Zero Clearance	Yes	Yes	meet Rheem exceed market
Operating Modes	5	5	meets market
CTA-2045	✓	✓	exceed market
Sound (dBA)	49	49	exceed market
Duct Ready	✓	✓	exceed market
Leak Sensor Ready	✓	✓	meets Rheem exceed market
Water Shut Off Valve Ready	✓	✓	meets Rheem exceed market
Refrigerant	R134a	R134a	meets market



Rinnai Electric HPHW – Key Components

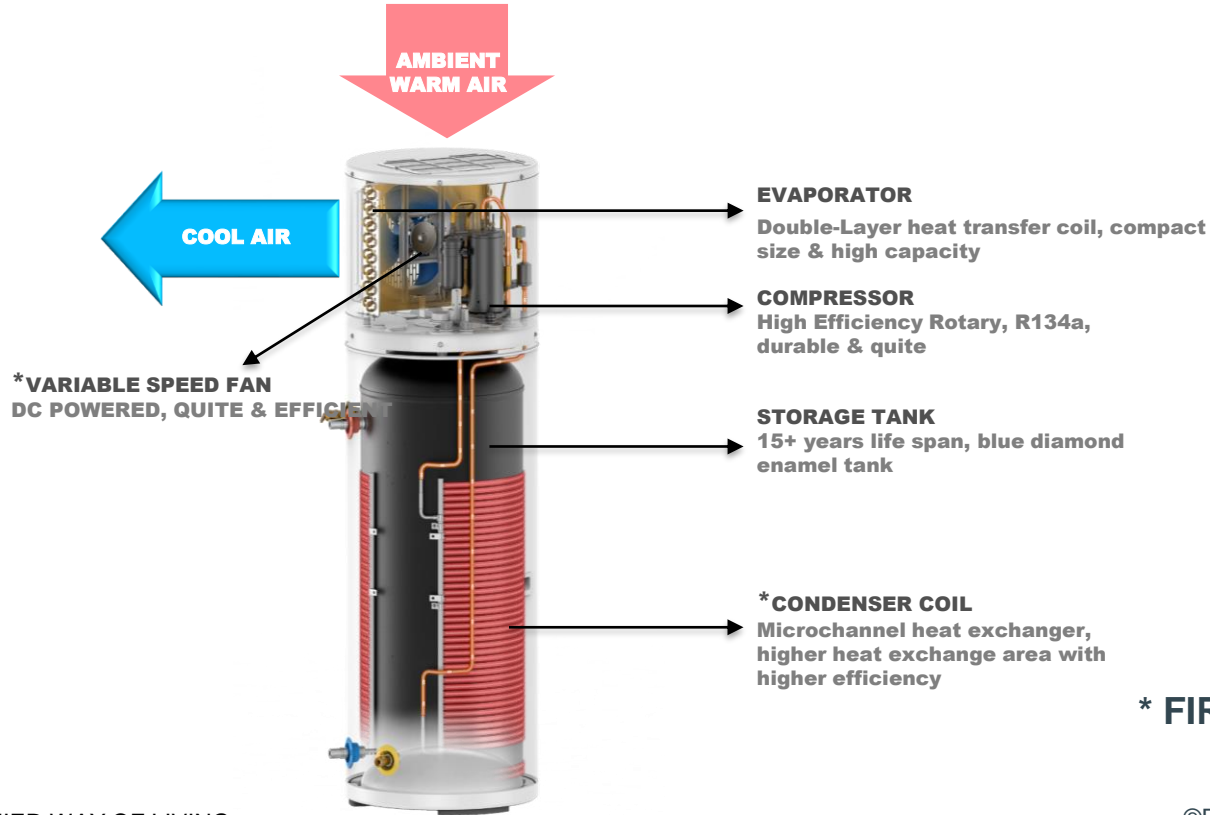

*** FIRST to Market**

Cross Reference for replacement application



Electric	HPWH
40G	40G/50G
50G	50G
65G	65G
80G	80G



Gas	HPWH
40G	50G
50G	80G
75G	2-50G

HPWH Product

- Accepting orders June 1st, 2024
- First ship date is July 1st, 2024

Heat Pump Companion

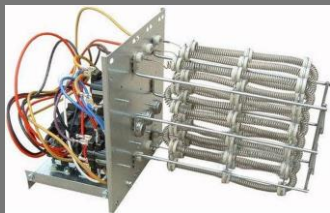

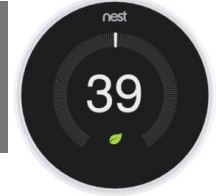

Heat Pump Companion – Overview

Solution: Heat Pump Companion

- ❑ Efficiency: Higher efficiency of hydronic heat
- ❑ Power outages – less strain on electric grid leading to less potential brownouts
- ❑ Lower operating costs – gas is less expensive than electric heat
- ❑ Comfort – less dry air and no moldy smells
- ❑ Potential local gas and electric utility rebates



HP Companion Product

- Accepting orders March 1st, 2024
- First ship date is April 1st, 2024

Support

Customer Centric Support



David – Master plumber with 30+ yrs experience

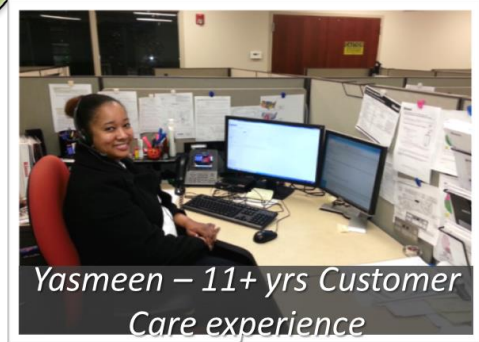

Yasmeen – 11+ yrs Customer Care experience

Guaranteed

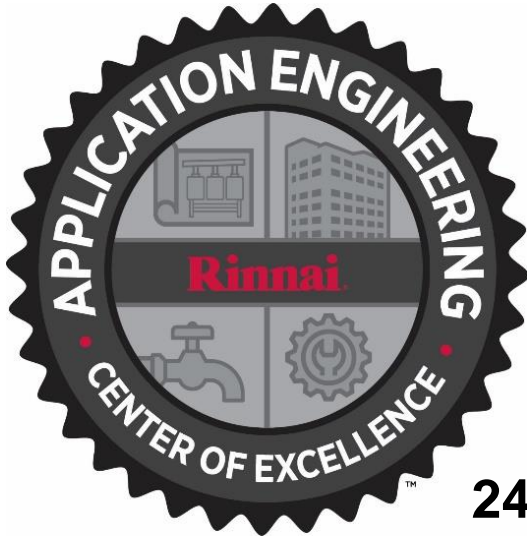

8:00AM – 8:00PM EST

***100% Sizing Guarantee**

24/7/365 Technical Support | 866.383.0707 |
engineering@rinnai.us

* No change in original fixture list and design parameters

Thank You