

6036 DS

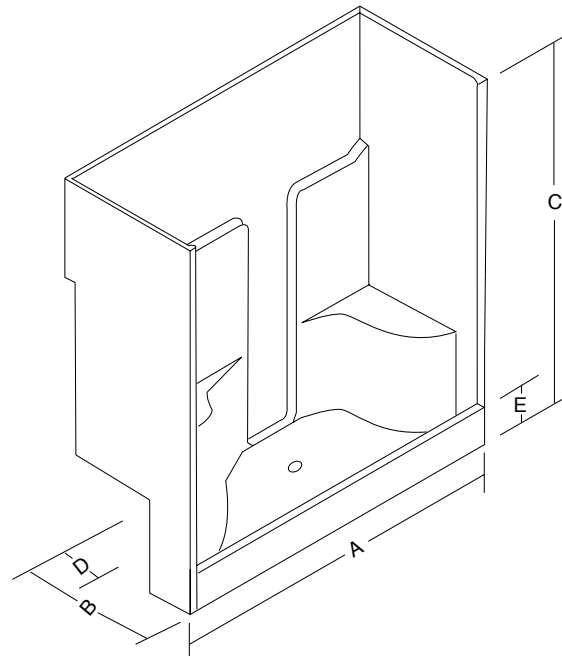

MODEL	A	B	C	D	E	Door Opening	Cap Optional
6036 DS	60 ¹ / ₈	35 ¹ / ₂	79	15 ¹ / ₂	6	56	Yes
<i>Shodor 350-56x70/650 - 56 x 71¹/₂/791-56 x 68¹/₂</i>							



Specifications

The shower unit shall be a gel-coated, heavy-duty fiberglass reinforced unit to provide a sanitary, unbroken, smooth surface.

Reinforcing and contouring gives added strength. The units shall have one inch nailing flanges on front and top edges and warranted against factory defects for three years.

All product measurements are to the outside of nailing flange. Measurements plus (+) or minus (-) 1/4".

All Venco Products are Canadian Standards Association certified



7584 Vantage Place, Delta, BC V4G 1A5
Phone (604) 940-4960 • Fax (604) 940-9733
email: venco@telus.net
www.venco.ca